

The Future for SMPS Magnetics

Weyman Lundquist

President and CEO
West Coast Magnetics



ISO9001:2008
ISO13485 Registered



How Much Smaller Can SMPS Power Magnetics Get? How Quickly?

- How much can we reduce the size of SMPS magnetic components, now and in the future?
- Let's try to answer this question by holding temperature rise constant, even as size declines.
- The focus is on loss reduction and as such will not look at cooling techniques (forced air, cold plate), or methods of reducing internal hot spot temperature such as potting.
- The projections are based on a transformer model, although many of the same conclusions will apply to inductors.



Outline

Where do device losses come from?

How much improvement is available from packaging?

Core material improvements, and future forecast.

How much power density improvement is available today?

What is the forecast for winding losses?

What can we expect from increasing the operating frequency?

Where will we be in 10 years?

Where are we headed in 20 years+?

.



Where do Losses Come From?

Typical 1500 W Transformer, 250 kHz

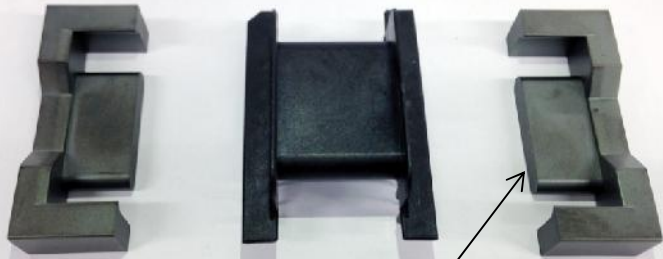

Core cross sectional area
(A_e)

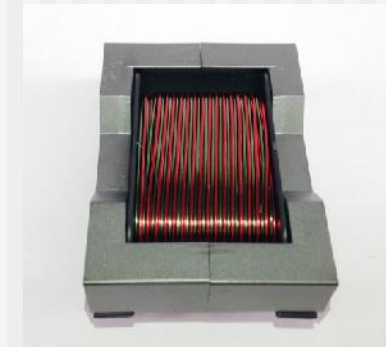
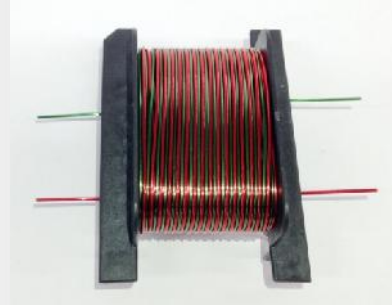

Core Loss: 4
Watts

Winding Loss:
3 Watts

Total Loss: 7
Watts

Efficiency 99.5%!



west coast
magnetics

Effective Use of Available Volume

Current Typical ETD49

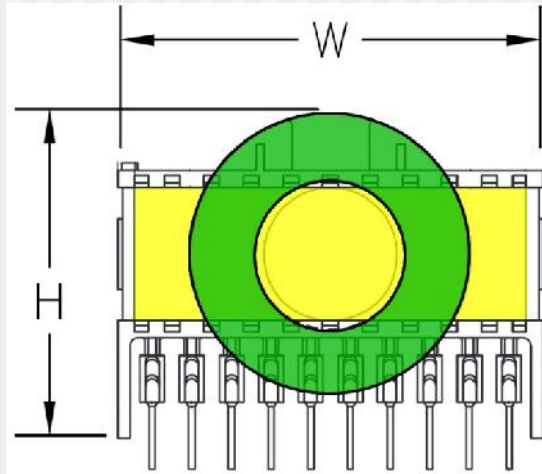

Full Cube = $L \times W \times H = 101 \text{ cm}^3$
Watts/cm³ = 11.2 *

New Design

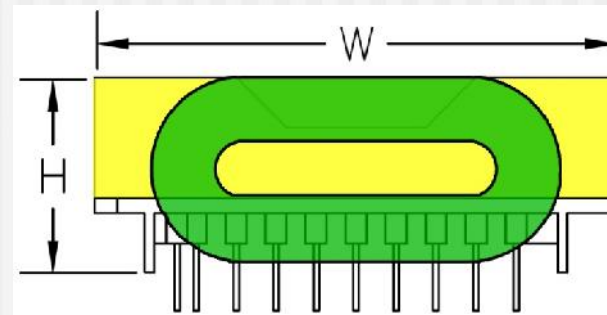

Full Cube = $L \times W \times H = 91 \text{ cm}^3$
Watts/cm³ = 16.5 *

* Power rating based on constant temperature rise design same core and winding technology used for each device.

Improvement Available Today = 47%



What is the Potential for Improved Packaging?

% of Total Device Cube That is Core Volume and Winding Volume Only

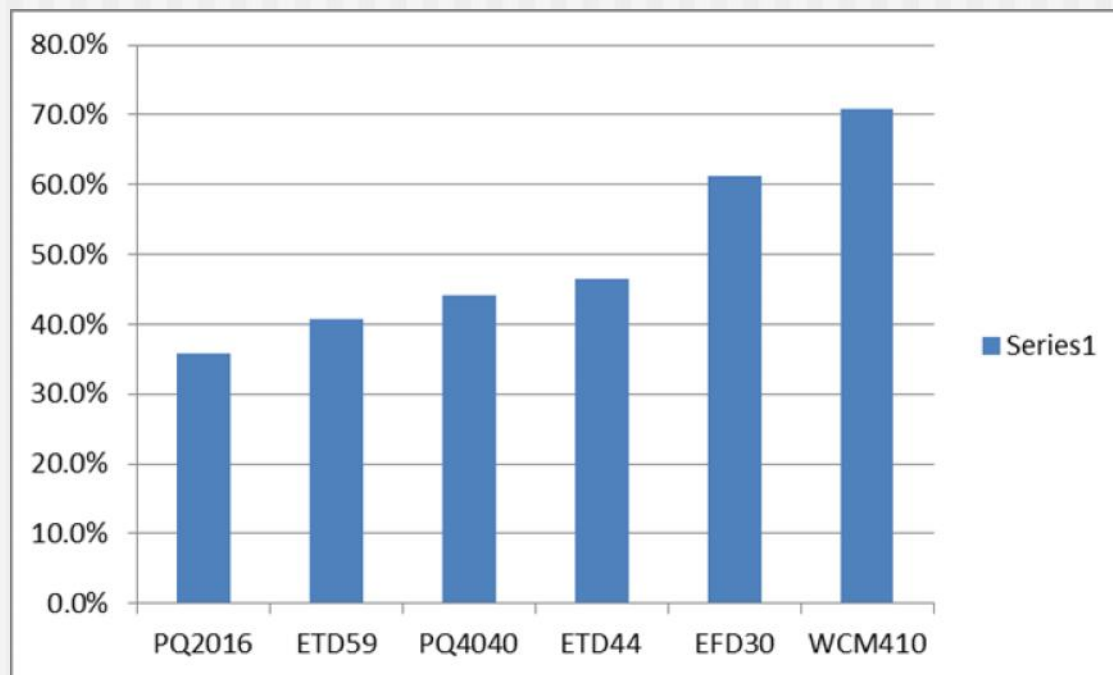

Improvements to 80% or higher will be possible with improved insulating materials and better use of existing materials.

Core Losses



$$AN = \frac{E_{rms} (10^8)}{4.44Bf}$$

Where:

B = peak AC flux density (gauss)

E_{rms} = rms primary voltage

A = core area, (cm^2)

N = number of primary turns

f = operating frequency

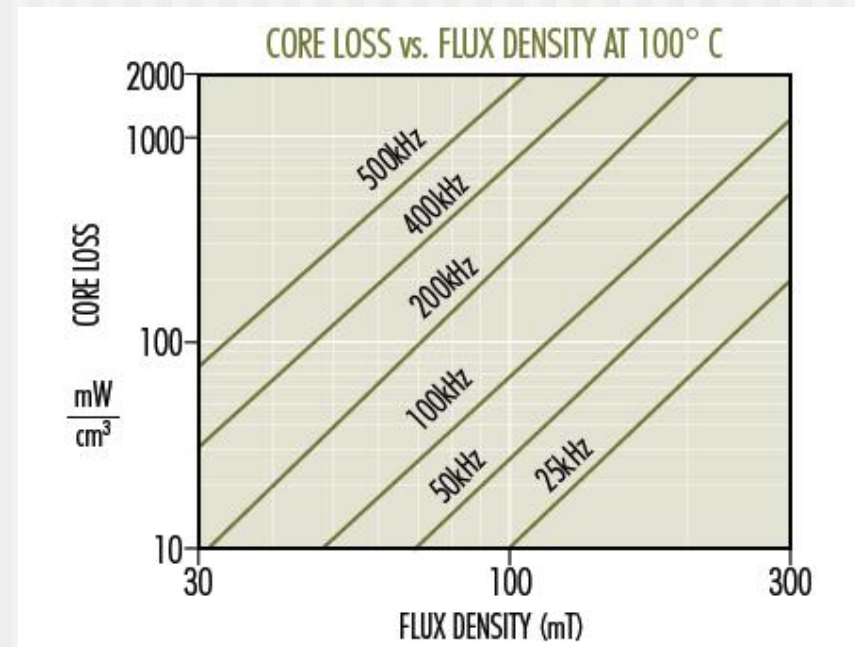

To reduce the size of our transformer we want to find a better material that will allow us to increase the value of B while holding the frequency and core loss density constant. This enables the use of less turns (lower winding resistance) and a smaller core.

What Does the Future Hold for Improved Core Materials?

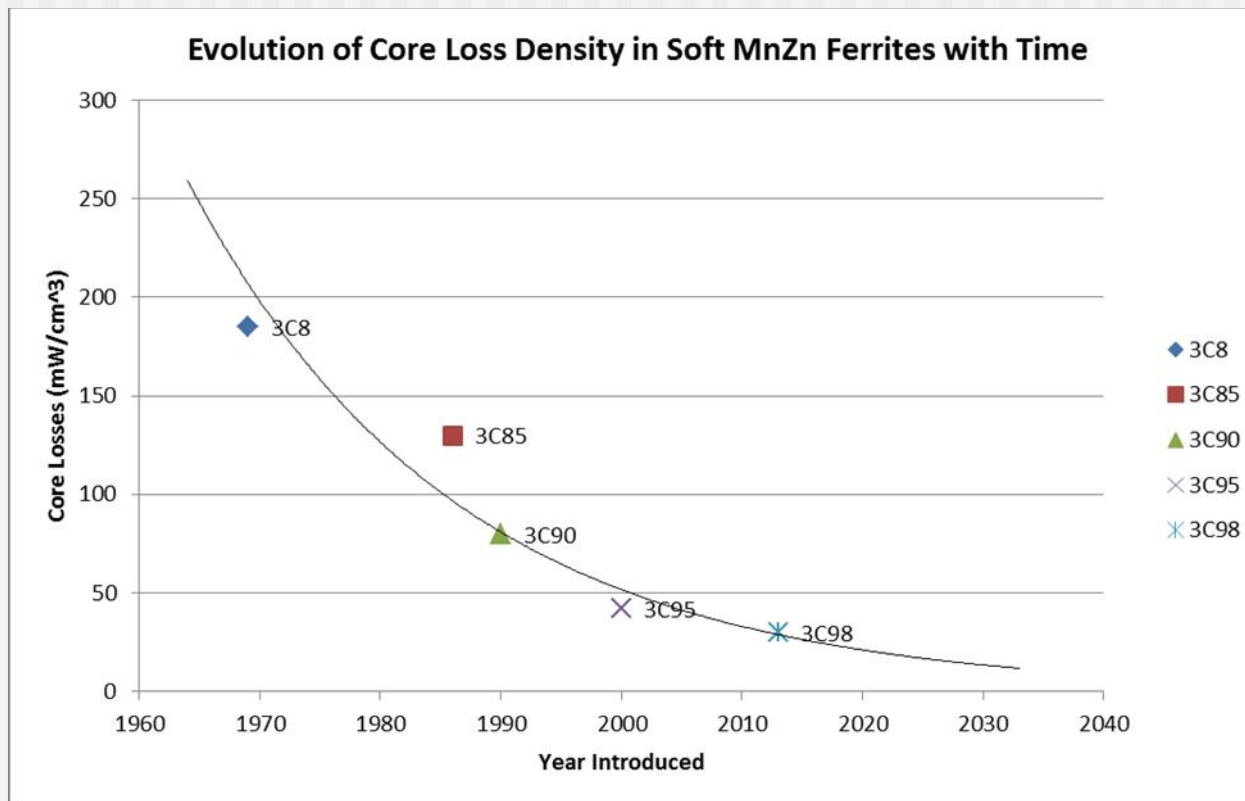

4.7%
avg. annual
reduction
in core loss
from 1969 to
3C98
introduction
in 2013.

Source: Ferroxcube, Core Loss at 1 kGauss, 100 kHz



What Core Materials are Being Chosen for Today's Designs

Stocking Quantities through U.S. Distribution

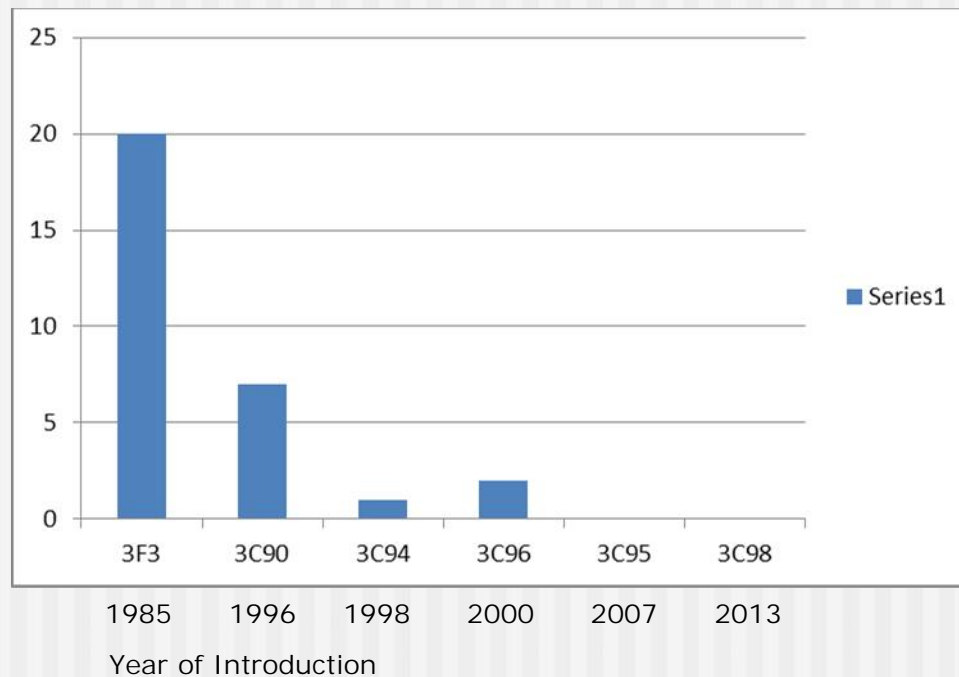

The presenter is certain that many new designs use core materials from 10+ old releases

Improvement available today: 50%



Improvement Available Today – More Efficient Packaging and Lower Loss Core

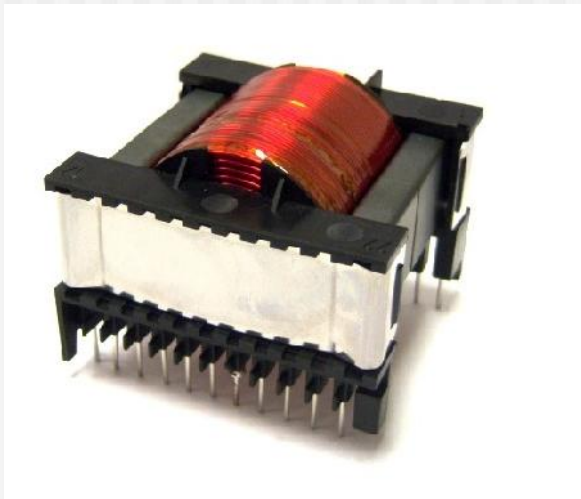

Full Cube = $L \times W \times H = 101 \text{ cm}^3$
Watts = 2400 at 100 kHz
Watts/cm³ = 23.7



Full Cube = $L \times W \times H = 91 \text{ cm}^3$
Watts = 4300 at 100 kHz
Watts/cm³ = 47.3

IMPROVEMENT 2.0 times power density



How About Winding Losses, What Can We Expect in the Future?

- Copper and Aluminum are going to remain the materials of choice for at least 10 years.
- Good News: Cu and Al have relatively low resistivity and low cost.
- Good News: Litz wire can be used to manage high frequency winding losses up to about 1 MHz but cost is higher with higher frequency.
- Bad News: Litz wire suitable for frequencies over 1 MHz is very expensive.



What About the Effect of Increasing the Operating Frequency?

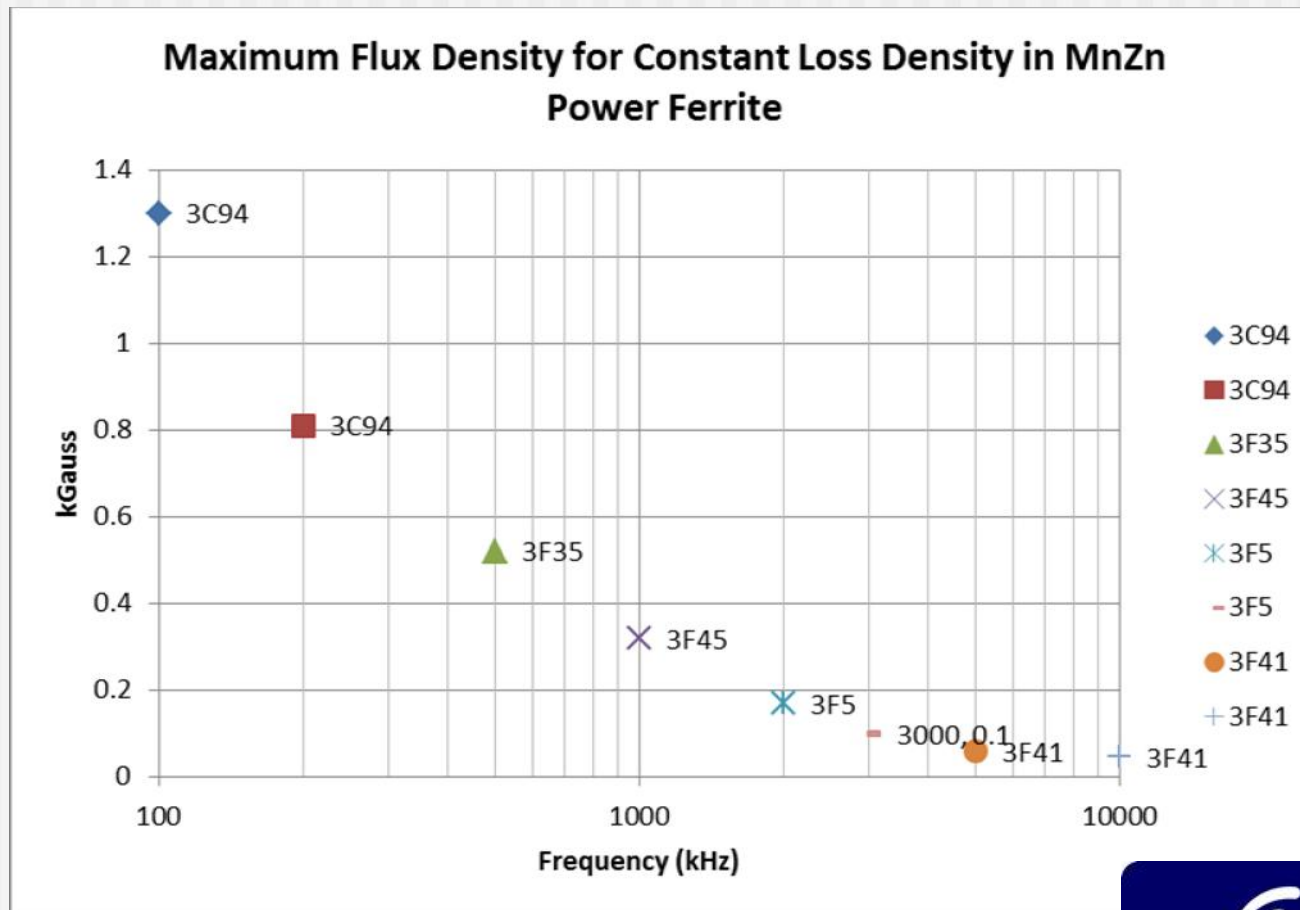

Source: Ferroxcube



Device Size vs. Frequency – State of the Art Today

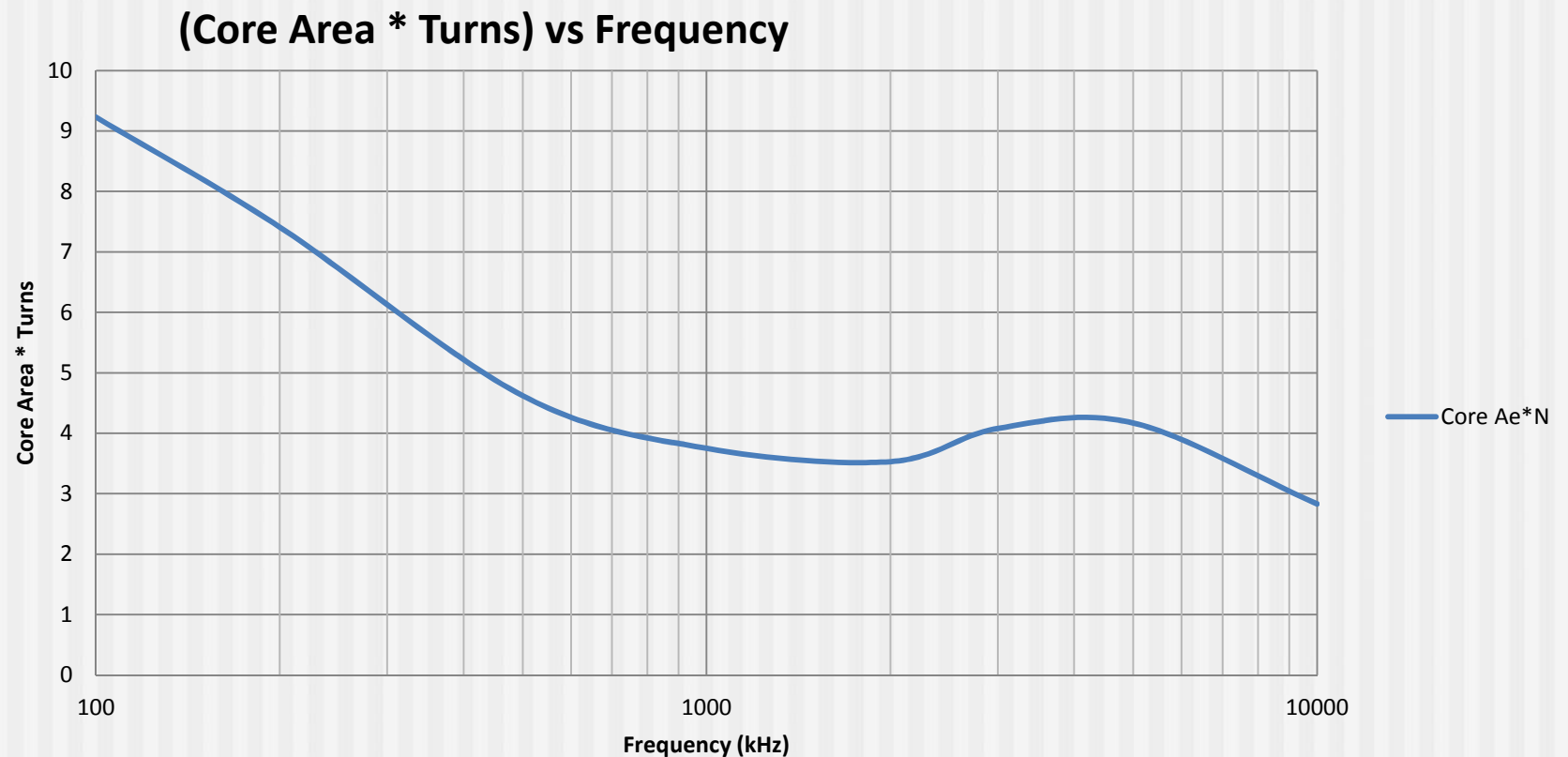

10 Year Forecast

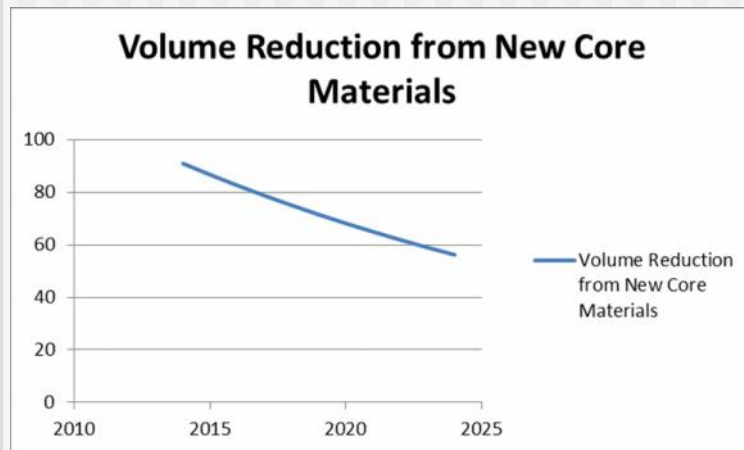

38% overall reduction in device volume

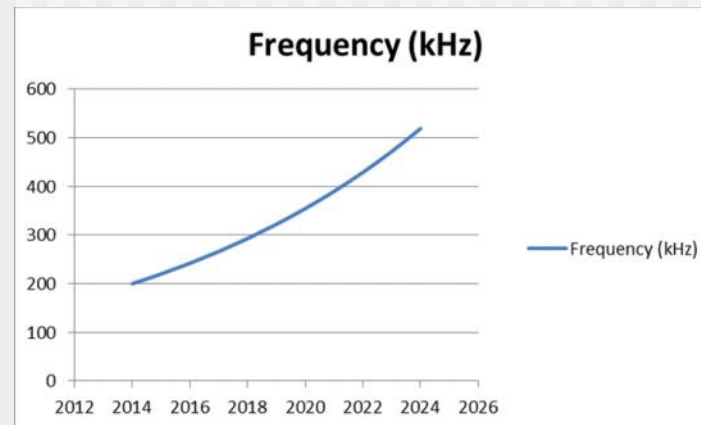

Operating frequency will increase more quickly at 10% per year. This will result in an additional 30% reduction in device volume.

Conclude: we can expect a decrease in device volume or increase in power density of at least 50% over the next 10 years as a result of better core materials and increased operating frequencies.



Further Out Approaching 20 Years and Beyond

Approaching 20 years I expect to see device sizes in the range 20% to 30% of today's volumes from more efficient use of available volume, improved core technology, improved winding technology and increasing frequency of operation to the 1 MHz range.

Current ferrite core technology does not lead to reduced device size over 1.5 MHz.

Litz wire is too costly and makes poor use of winding area for gauges suitable for frequencies over 1.5 MHz.

Development of new core materials, and new winding technologies is needed or device size will plateau as we approach the 20 year mark. This development will happen.



Conclusions

For many designs it is possible to double the power density with material options available today.

Over the next 10 years it is expected average device volume will be cut in half due to improvements in core materials and increases in switching frequencies.

This improvement is expected to extend out to 20 years with device sizes as small as 20% of today's typical devices.

From 1.5 MHz to 10 MHz more development work is needed for further size reduction on both the core material side and the winding side. This is expected to occur.



Thank you for your time

Weyman Lundquist, President
West Coast Magnetics
4848 Frontier Way, Ste 100
Stockton, CA 95215

www.wcmagnetics.com

800-628-1123



ISO9001:2008
ISO13485 Registered

