

EnABLES – Free of charge power IoT feasibility studies undertaken



Presented at APEC 2022 IS24 – Energy Harvesting



Presentation Content

1. What is the power IoT challenge?
2. What is EnABLES?
3. EnABLES innovation and impact
4. EnABLES TAs (Transnational Access projects)
5. TA use case examples (from Tyndall)
6. Other TAs (consortium)
7. TA testimonials
8. Summary & Conclusions



What is the Power IoT challenge?

We MUST find ways to make batteries last longer – how?

1. Make batteries that supply more energy
2. Reduce power consumption of the IoT device
3. Use ambient energies – Energy Harvesting

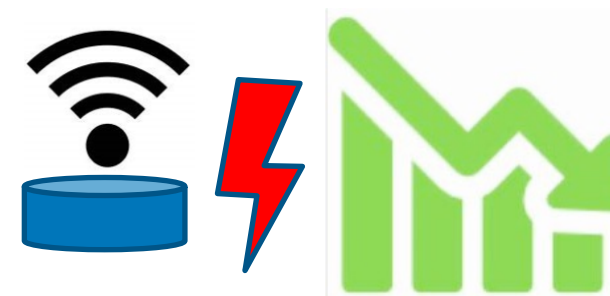

Heat (thermoelectricity)



Vibration/kinetic



Solar (PV)



Our Power IoT ecosystem

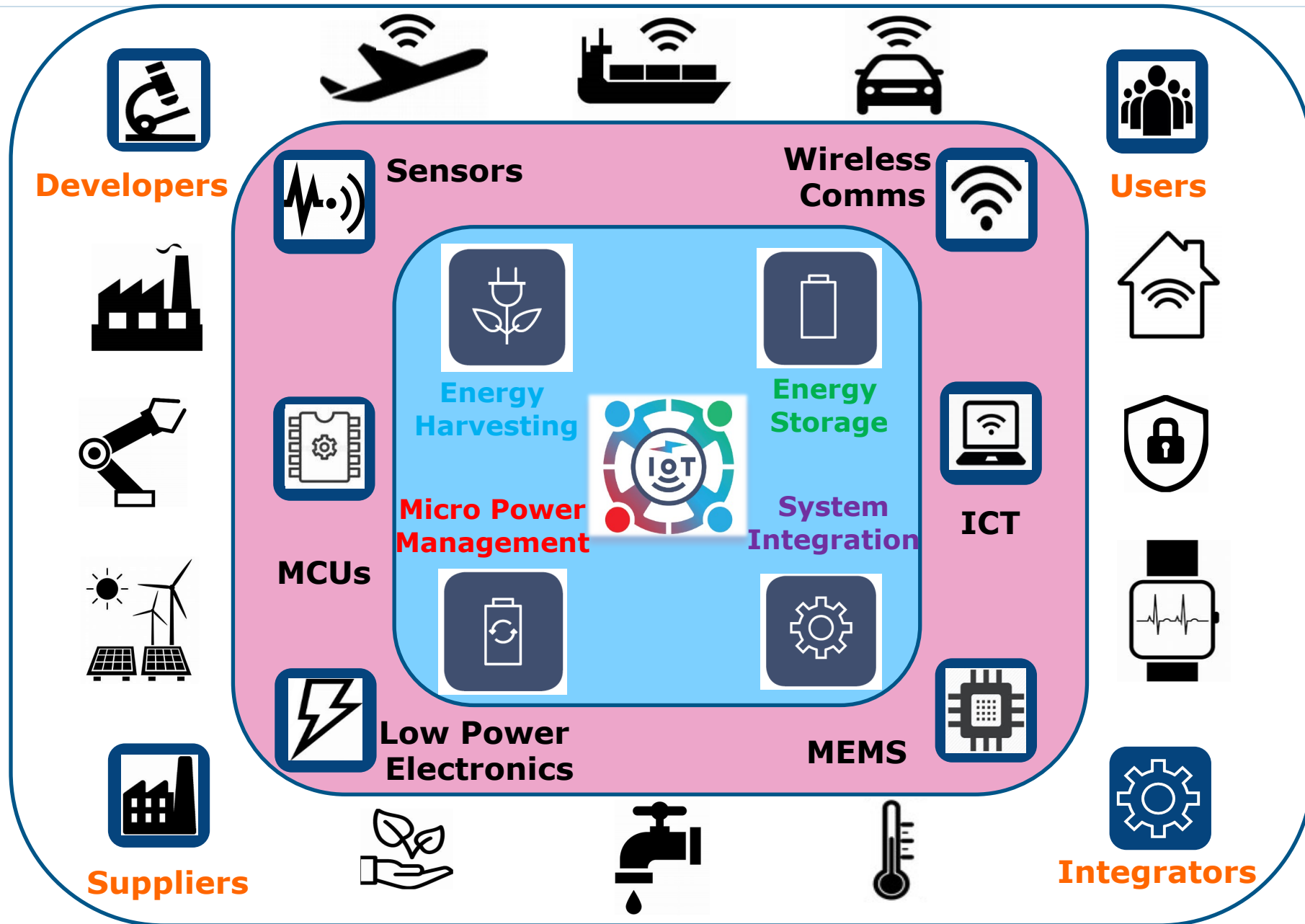

PSMA has been a key collaborator in building this ecosystem



EnABLES - Quick introduction



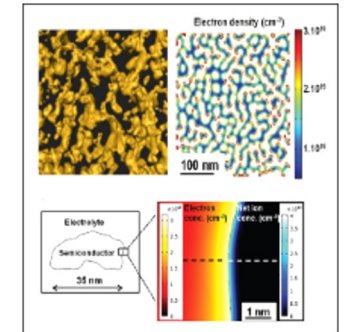
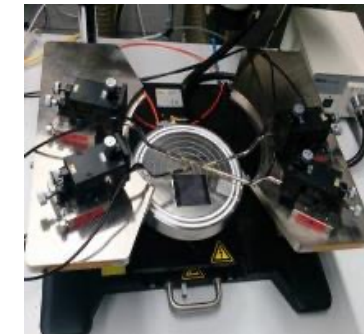
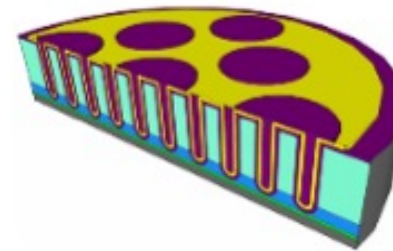
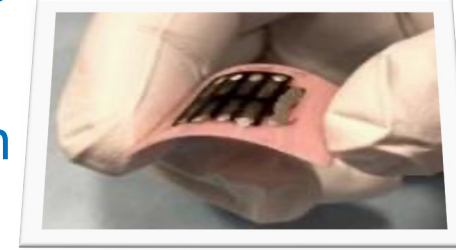

- Builds an ecosystem to power the internet of things
- Driving system level thinking & optimization
 - Via collaboration, inter-operability, standardization
- Its Transnational Access (TA) program gives
 - **Free of charge** access to expertise & laboratories
 - Feasibility studies
- Joint Research Activities (JRAs) are creating
 - System optimised, application orientated solutions
 - De-risked & standardised methodologies & library parts

Done by project partners listed below

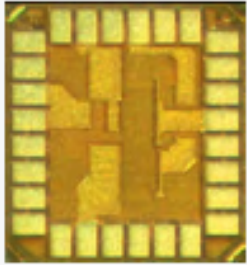
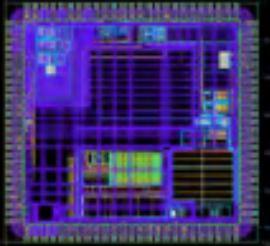
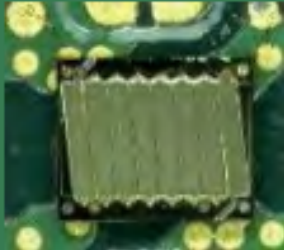

EnABLES– Innovation and Impact (from position paper)

Innovation	Impact/progress beyond SoTA
<p>Micro-power Discrete & PMC circuits</p> 	<p>Extract tiny ambient energies that currently are unusable. Extend battery life.</p>
<p>Ultra wide I/P, O/P voltage PMIC</p> 	<p>Huge range of ambient energies usable. x2 to x7 battery life extension, autonomy in some cases</p>
<p>Think film inductor compatible with Si fab</p> 	<p>Embed and miniaturize power sources</p>
<p>Solid state Li- based batteries</p>  <p>truly solid hybrid electrolyte</p>	<p>High density, rechargeable, safe. Wider range of real life applications</p>



EnABLES– Innovation and Impact

Innovation

Impact/progress beyond SoTA

Nano materials for storage – cathodes, electrolytes

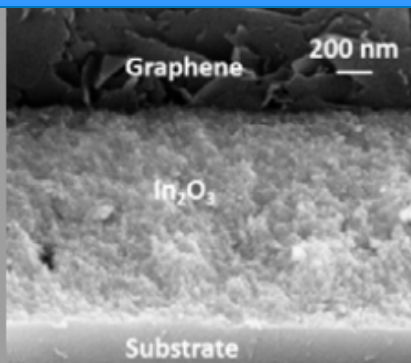

X10 times higher density
Longer life, wider temp. range

Printed electronics e.g. electrolyte gate transistor

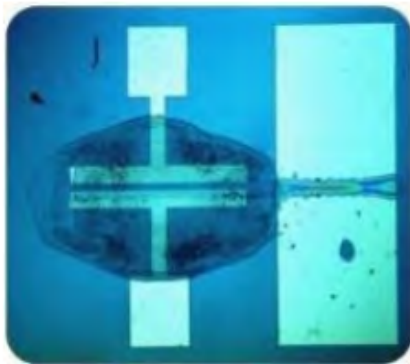

Non toxic materials, more environmentally friendly.
Flexible for wearables

Flexible antennae for wearables



Embed in wearables – assisted living, sports, patient monitoring, etc.



EnABLES– Innovation and Impact

Innovation

Impact/progress beyond SoTA

**Micro-power
Non linear
vibrational
harvester**

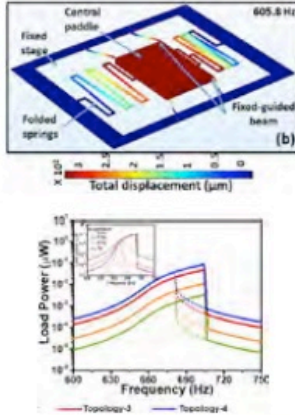

Responsive to changes in vibration frequency and amplitude

**Self-tuning
vibrational
harvester**

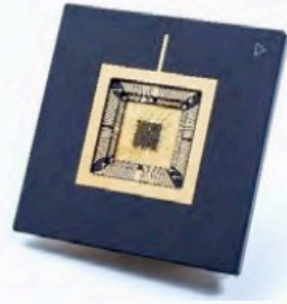

Automatically maximises energy harvested

**Self-powered
wireless
sensor
platform
BlueTEG**

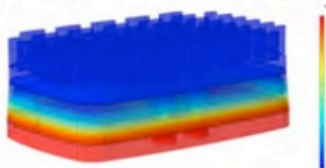

Uses heat (or cold) to power the sensor
Check operation and safety (e.g. leaks)

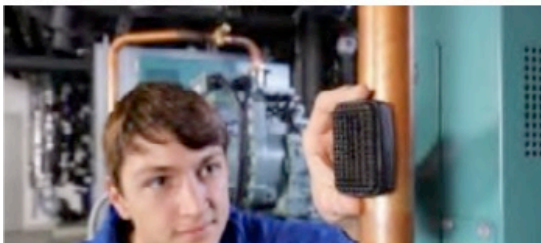

EnABLES Transnational Access Program

Free of charge access to equipment, tools and expertise to do 'powering IoT'* feasibility studies in research centres across Europe

- paper, simulation, prototype
- characterisation, system optimisation

Virtual Access to databases of 'real life' vibrational energy sources

Open to industry and academia: researchers, developers, integrators of IoT materials, devices and systems

**Reduce power and/or use energy harvesting*

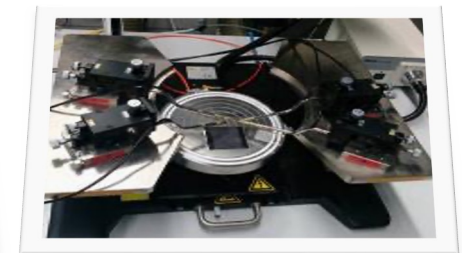

Use Case: Aircraft Tracking Devices

Concept

- Want to track 'what kind of journey' a **ULD*** and its contents have had
 - Where was/is it? Was is safe and compliant?
- Some ULDs have their own climate controls, esp. for functionality and regulatory reasons e.g. pharmaceutical
- Battery life 12-18 months, needs improvement, target > 5 years (min. 3)

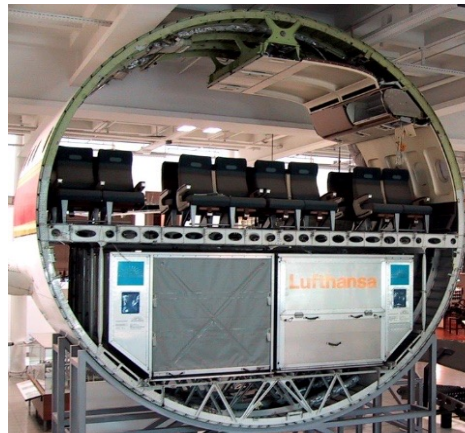

* Universal Load Device



Making cargo talk!



Use Case: Aircraft Tracking Devices

Sensing

- Temperature/Humidity
- 3D Acceleration/3D Compass
- Pressure/Sound
- Electrical Power Signals 50/60/400Hz

Tracking

- Real-time Location tracking approaches include use of
 - RFID tags
 - GPS
 - Mobile
 - Bluetooth Low Energy (BLE)
 - Long Range Wide Area Network (LoRaWAN)

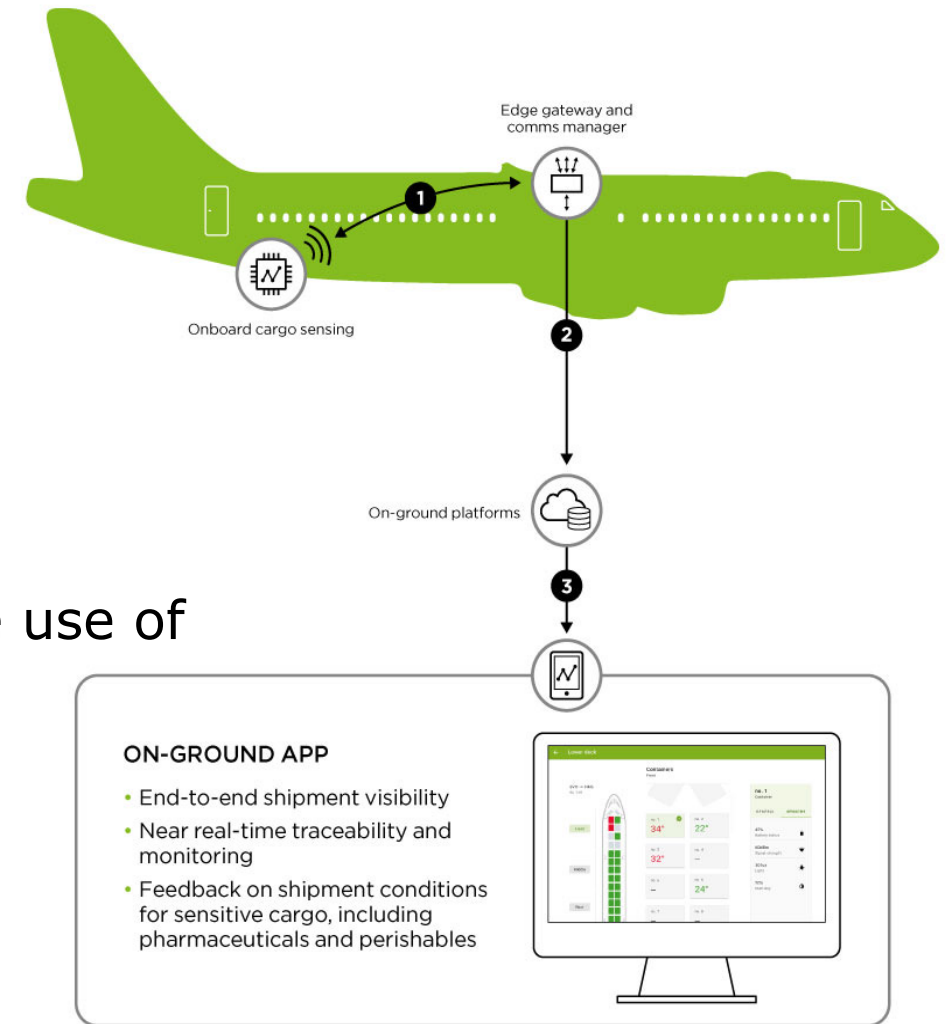

Use Case: Aircraft Tracking Devices

Sensing

- Temperature/Humidity
- 3D Acceleration/3D Compass
- Pressure/Sound
- Electrical Power Signals 50/60/400Hz

Tracking

- Real-time Location tracking approaches include use of
 - RFID tags
 - GPS
 - Mobile
 - Bluetooth Low Energy (BLE)
 - Long Range Wide Area Network (LoRaWAN)

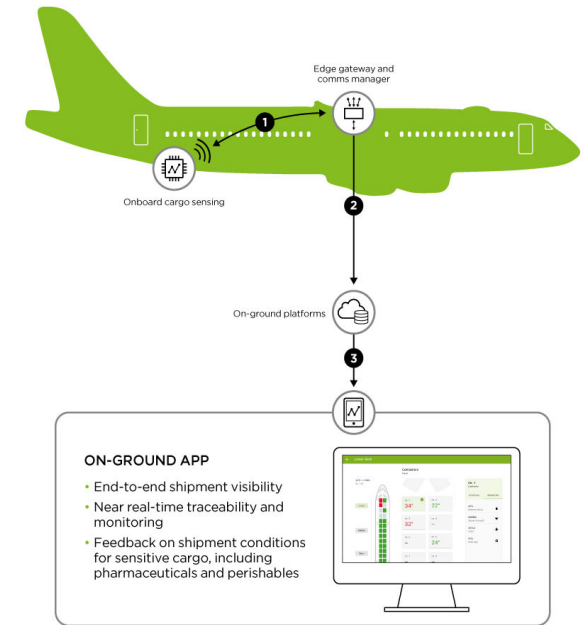

Use Case: Aircraft Tracking Devices

Study content

- Investigate how to minimize the power consumption of existing and emerging technologies
- Analysis of power requirements of current solutions
- Investigate the real life ambient energies available for Energy Harvesting

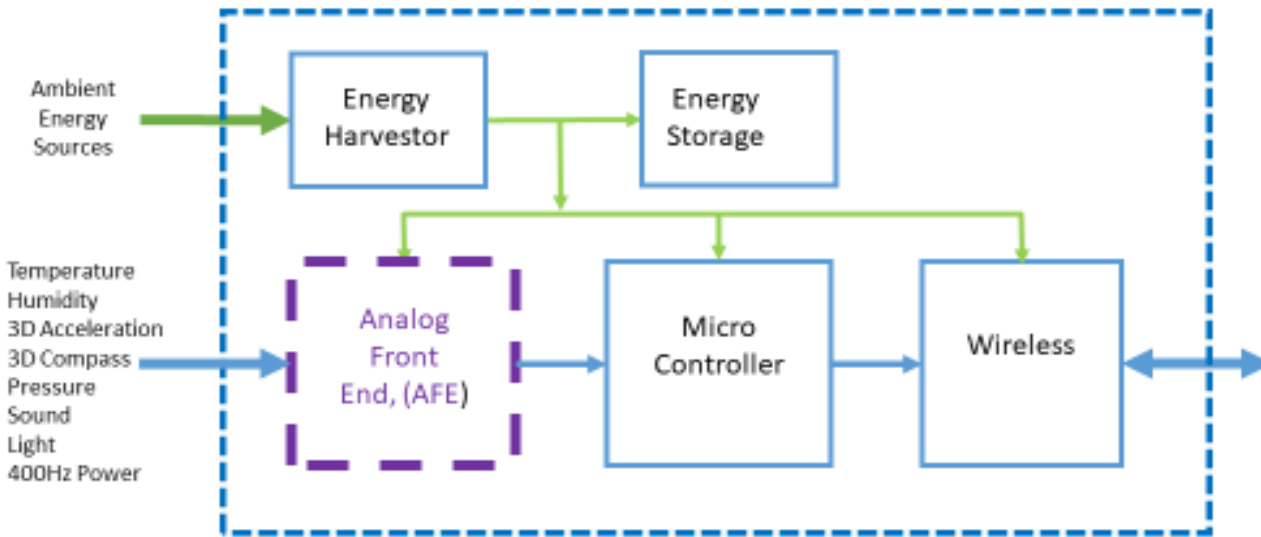

Energy-harvesting-powered system

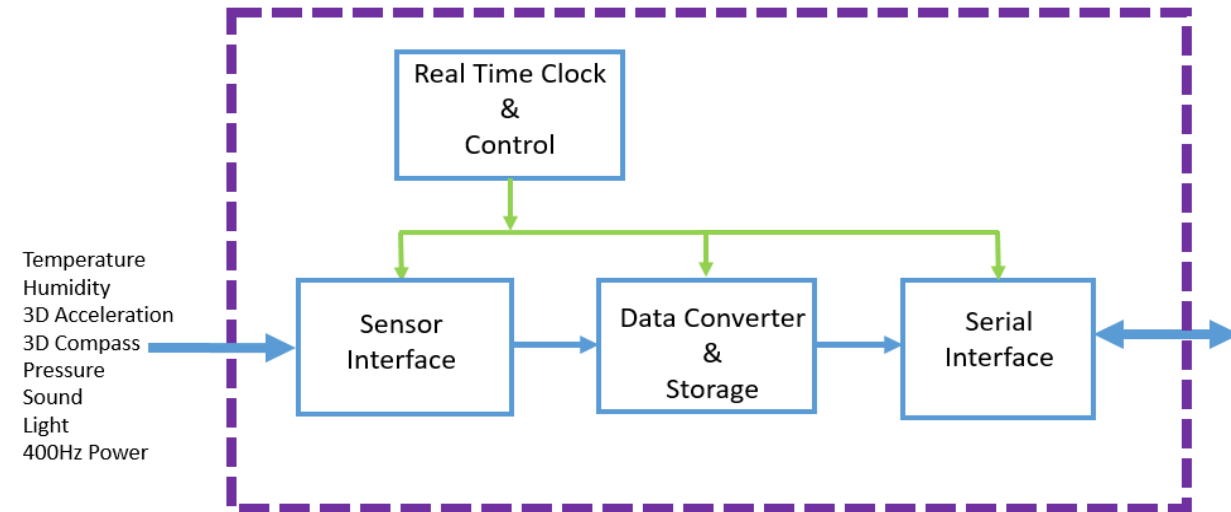

AFE detail (Analog Front End)



Use Case: Aircraft Tracking Devices

Outcome

- Energy harvesting power architecture devised
- Innovative contextual control/detection circuit proposed that only activates various parts of the system when needed (Tyndall/Swiss Airtainer confidential)
- Reduction in power from 10mA (current system) to 50uA with Automatic Dependent Surveillance–Broadcast (ADS–B)
- 3 year battery life with 1.5Ahr (Versus 1 year and 90Ah currently)!
- PV panel 50x50mm (2"x2") is sufficient to power autonomously
- Can be further reduced to 11uA if ADS-B is not needed

* Surveillance technology in which an aircraft determines its position via satellite navigation or other sensors and periodically broadcasts it, enabling it to be tracked. Also enables situational awareness (nearby aircraft).

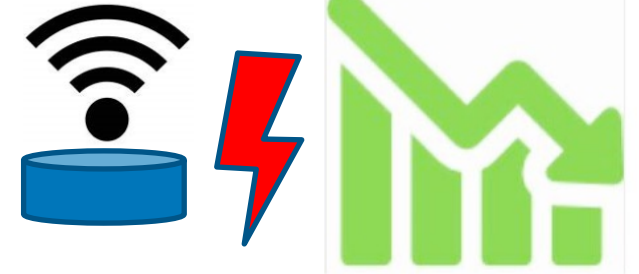

Use Case: Structural Health Monitoring (SHM)

Concept

- Can we use **neural networks** to create **self-powered & self-repairing/fault tolerant** WSN SHM solutions?
 - Use EH (energy harvesting) as a power source
 - Detect anomalies & re-route data (temp, vibration, pressure, displacement)
- Similar to how a brain re-routes data if damaged
- **Example:-** In the 50 year monitoring of a bridge, *even if 5-10% of the wireless sensors fail*, can the remainder of the system still gather data & supply sufficient information?
- Interpolate between missing data points or infer from adjacent sensor data
- Re-route around damaged sensors & gateways



Use Case: Structural Health Monitoring

Initial discussions outcome - 'Little-Big' architecture proposed

- Simplify functionality of 'little processors' (95%+ of wireless sensors used)
 - Take instructions from 'big processors'
 - Transfer data over short distances to a nearby big processor
 - Do minimal processing to minimize power and enable EH
- 'Big processors' run the algorithms that will re-route little sensor nodes if needed or wake up more frequently if more data needed
 - Connect to the cloud via 5G, LoRA or whatever (data comms &/or processing)
 - Bigger battery + EH source needed but not many required

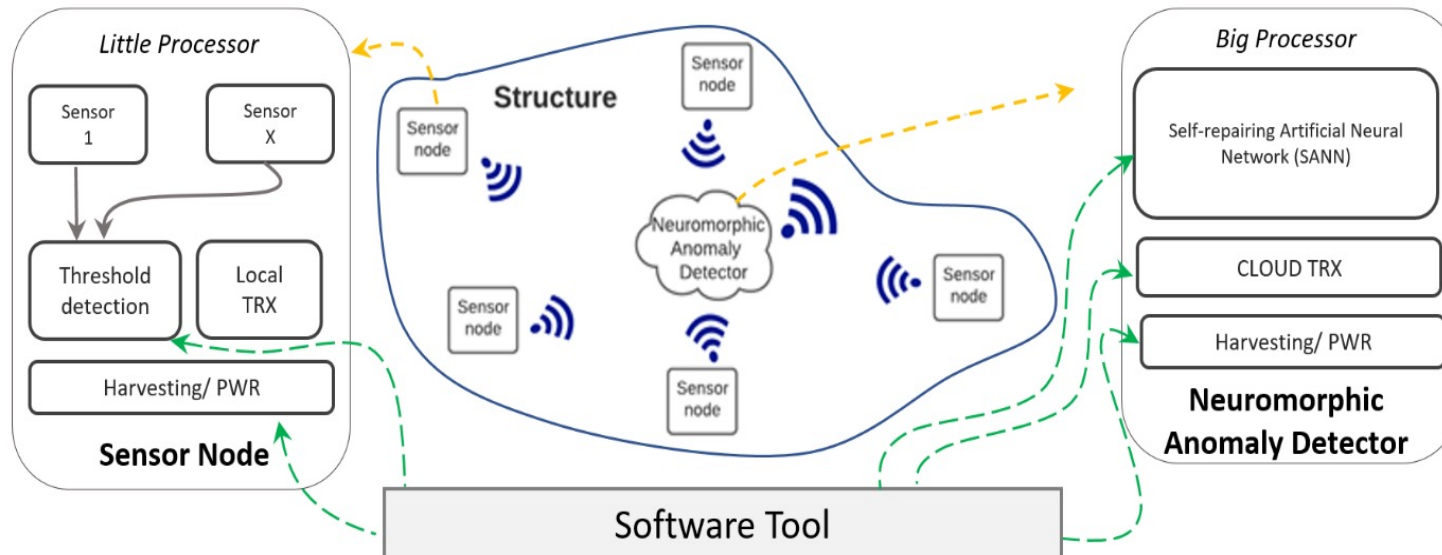

Use Case: Structural Health Monitoring

Feasibility study activities

- Build on the 'little big' architecture concept
- Develop simulation tool to help select optimum little and big processor
- Integrate neural network algorithm 'power loading implications' from a UU (Ulster University) software tool
- (Bring 'thinking about power' to the forefront)
- Estimate battery/life and potential extension with various EH solutions



Use Case: Structural Health Monitoring

Progress to date (Started Dec 2021)

- MATLAB simulation tool created
- Trawling through datasheets to capture processor data
- Some system level characterization might be needed (not always easy to extract from datasheets)
- Working with UU to understand power loadings versus algorithm used and how to integrate into the model

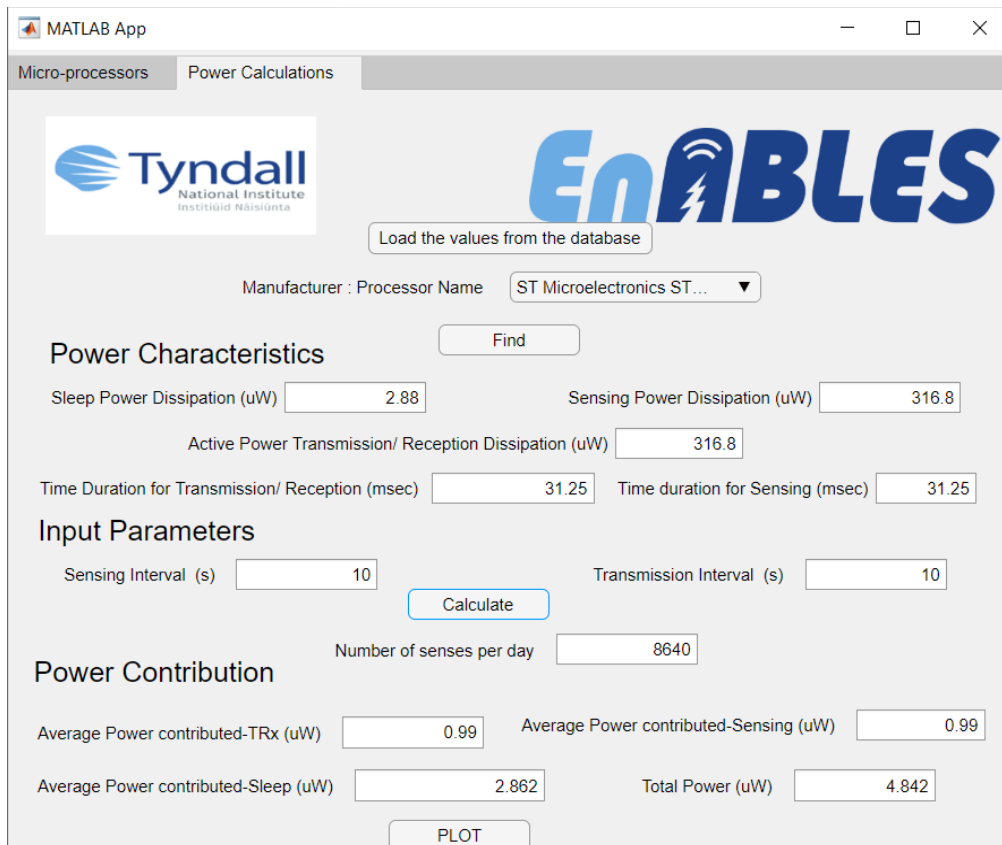

The image shows a MATLAB App window titled "MATLAB App" with a "Power Calculations" tab. The interface includes the Tyndall National Institute logo and the "EnABLES" logo. A button labeled "Load the values from the database" is present. Below this, a dropdown menu shows "Manufacturer : Processor Name" with "ST Microelectronics ST..." selected. A "Find" button is located below the dropdown. The "Power Characteristics" section contains input fields for "Sleep Power Dissipation (uW)" (2.88), "Sensing Power Dissipation (uW)" (316.8), "Active Power Transmission/ Reception Dissipation (uW)" (316.8), "Time Duration for Transmission/ Reception (msec)" (31.25), and "Time duration for Sensing (msec)" (31.25). The "Input Parameters" section has "Sensing Interval (s)" (10) and "Transmission Interval (s)" (10) with a "Calculate" button. The "Power Contribution" section shows "Number of senses per day" (8640), "Average Power contributed-TRx (uW)" (0.99), "Average Power contributed-Sensing (uW)" (0.99), "Average Power contributed-Sleep (uW)" (2.862), and "Total Power (uW)" (4.842). A "PLOT" button is at the bottom.

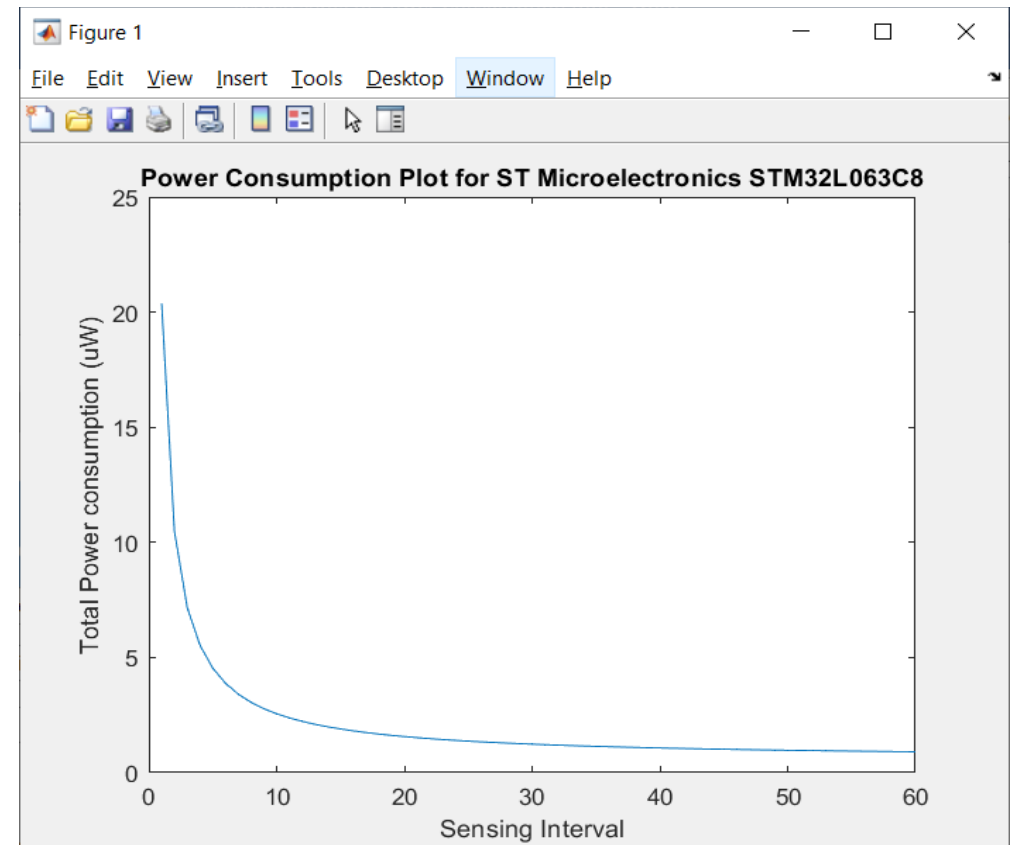

Use Case: Batteries for med tech applications

Feasibility study activities

- Do a state of the art review to guide their selection of suitable battery technologies
- Based on a typical high level spec for current COTS wearable devices
 - Includes form factor and end of life considerations
- Also to prompt others to 'weigh in' and give industry guidance
(Bring 'thinking about power' to the forefront)



SANMINA®



<i>Characteristic</i>	<i>Requirement</i>
Voltage	3 V
Supply Capacity	400 mWh (minimum)
Peak discharge capabilities	100 mA
Chemistry	Single use, non-rechargeable
Active Life	3 days
Shelf-life	> 2 years
Cost	Low
Form	Small, flexible if possible
End-of-Life	Suitable for incineration



Use Case: Batteries for med tech applications

Feasibility study outcome (some extracts)

- Five unique commercially available battery types analysed for suitability
- Commercial batteries do not provide sufficient supply capacity to provide 400 mWh with period pulses up to 100 mA
- Some can be stacked together to achieve the necessary capacity at a nominal discharge rate but the actual working capacity would likely be greatly reduced due to the periodic high current pulses.
- Much research being conducted in flexible zinc-air batteries but only rigid-type batteries are currently available
- Zinc-air batteries are high density but incapable of handling current pulses
- Zinc-silver oxide SR44 battery was the most suitable candidate. If pulse discharge capacity is insufficient due then consider lithium-based CR2032 model
- There is little data on impact of periodic high current pulses, so testing necessary
- Avoid Lithium batteries due to hazardous disposal material but can be 'last resort' if large discharge capacities needed



Use Case: Batteries for med tech applications

Summary table and weblink

- *Planning to publish in a forthcoming journal, will release details on PSMA & EnABLES websites shortly*

	Requirement		Silver Oxide	Alkaline	Zinc-Air	Zinc-Carbon	Lithium
Model	~		SR44	LR44	PR44	Enfucell Soft Battery	CR2032
Voltage	3 V		1.55 V	1.5 V	1.4 V	1.5 V	3 V
Connect in Series	~		Yes	Yes	Yes	Yes	No
Supply Capacity	> 400 mWh (> 133.3 mAh **)		160 mAh	120 mAh	610 mAh	90 mAh	230 mAh
Connect in Parallel	~		No	Yes	No	Yes	No
Number of Batteries Required *	~		2	4	2	4	1
Maximum Pulse Discharge	100 mA		~	~	16 mA	18 - 20 mA	~
Single Use	Yes		Yes	Yes	Yes	Yes	Yes
Weight	Light		2 g	2 g	1.8 g	2.9 g	3 g
Shelf-life	> 2 years		3 years	3 years	3-4 years	Min. 2 years	5-10 years
Cost	Low		Low	Low	Low	Low	Low
Form	~		Coin	Coin	Coin	Flexible	Coin
Dimensions	Small	<i>Diameter</i>	11.5 mm	11.6 mm	11.6 mm	Rect. (60 mm x 72 mm)	20 mm
		<i>Thickness</i>	5.5 mm	5.4 mm	5.4 mm	7 mm	3.2 mm
Suitable for incineration	Yes		Yes	Yes	Yes	Yes	No



Other TA Use Cases

To date we have 55 TAs in our pipeline

<https://www.enables-project.eu/stories/>

<https://www.enables-project.eu/webinars/>



EnABLES Project Ref No

097

User

Roberto Guarino

Affiliation

[Koral Technologies Srl](#), Trento, Italy

Description

Koral Technologies is working on the development of a multi-source energy harvesting platform, which is also based on flexible electronics for powering wearable or textile-based connected devices. The platform is based on the use of large-area flexible thermoelectric generators, which are currently poorly present on the market and only few suppliers are available. EnABLES allowed us to experimentally characterise these components. The results are useful not only for the scientific community, but also for supporting the product development activities of Koral Technologies, as well as for increasing its competitive advantage in wearable technologies.

Access provided: [Access to TEG Harvesting at Fraunhofer-IMS.](#)

Testimonial

"As a young start-up company, Koral Technologies has strongly benefitted from the joint project with Fraunhofer IMS. The EnABLES offer has allowed our company not only to complement our internal R&D effort through dedicated technical support, but also to put solid basis for the future development process and for the launch of our innovation on the market."



Home Offer ▾ News ▾ Users ▾ Events Join Network

#10: Energy Harvesting Solutions in Real World Use Cases – Part 2



[Click to watch](#)

#9: System-level simulation tools for power IoT solutions



[Click to watch](#)

#8: Printed Electronics for Energy Harvesting



[Click to watch](#)

Check out previous webinars,
some cover use cases



More TA examples can be found here

TA Testimonials (from position paper)

Swiss-based multinational: Determine whether RFID technology can be used to wirelessly monitor the temperature of heated food in a combined device consisting of an oven & microwave (FhG-IMS).



The wireless sensor transponder is supplied with energy via an independently transmitted electromagnetic field (microwave signal) and the sensor transmits data to a separate receiver station, called a reader.

"Fraunhofer IMS provided excellent knowledge on RF energy harvesting and wireless data communication. We are specialised in supplying sensors e.g. temperature sensors and sensor systems for many applications. The sponsorship by EnABLES allowed us to push into a new technical field of energy harvesting and wireless communication. To open up new applications, energy-autonomous sensors are an important factor in the future. We gained internal knowledge and were enabled to estimate necessary modifications on our products to allow an implementation of the studied technology. With the RF-harvesting technology we plan to expand our portfolio and serve a much bigger market in the future."

With the RF-harvesting technology we plan to expand our portfolio and serve a much bigger market in the future.

Italian University: Integrated software/hardware design approach to fabricate power-efficient multi-insulator tunnelling diodes for future 5G/IoT RF energy harvesting applications (Tyndall).



This was a study combining simulation models and hardware design methodologies to enable optimised tunnelling diode development and fabrication for real life applications of RF energy harvesting.

"The EnABLES contribution to our project is fundamental as it consummates the theoretical study with a real-world implementation of the suggested model. All the project members are just experts and liaise very well throughout the different project phases. The EnABLES application process was very simple and the outputs will guide and accelerate our development of tunnelling diodes from the fundamental concept phase. With the realized prototype, we aim to optimise power harvesting for millimetric frequency IoT devices, where there is a surge of interest from commercial partners and make them ready for future commercial applications."

With the realized prototype, we aim to optimise power harvesting for millimetric frequency IoT devices, where there is a surge of interest from commercial partners

This will result in materials that can deliver more energy in real-life applications.

Dutch SME: Characterise improved (as cast & annealed) TE materials for industrial applications (CEA-Liten).



Heat capacity properties were successfully measured up to 300°C confirming that the thermal conductivity reduction by doping precipitation is a viable route to reduce the thermal conductivity of thermoelectric materials. This will lead to higher power output TEG materials in the market.

"The dedication of the CEA team in providing the best measurement to support our development was an accelerator to give us valuable insight in the understanding of thermal conductivity reduction strategy for our doped material. This will result in materials that can deliver more energy in real-life applications. They provided all the required equipment and expertise to fulfill our need for this project and simplified the communication and the logistic. We highly recommend this free of charge and easy access to equipment and expertise to others."

TA Testimonials (SMEs) (from position paper)

Table 3 – EnABLES Transnational Access Testimonials

Table 3 – Continued

US Engineering consultancy: Characterize wireless sensor network system being developed to support a family of smart patch devices (Tyndall).

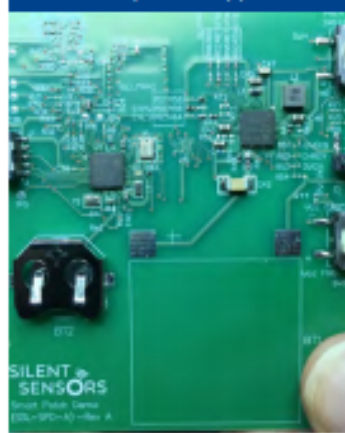

The feasibility study devised a methodology for characterising power consumption showing sensitivity to component selection and setting. It also created circuit and PCB layout recommendations so that in future designs it will be easier to decouple power consumption of individual components and circuits. This also makes it easier to simulate potential impact of using energy harvesting.

"Thanks to the EnABLES team and the EU for supporting my project. This gives us a solid basis for characterising and optimising power consumption of our next generation of devices as well as understanding the potential battery life extension if we use energy harvesting. This is an amazing transnational access program that provides little companies like mine to access billions of dollars in assets that never would have been available/affordable for us. Hope it continues and grows for others as well as our desire to utilise in the future. Thanks again for putting your resources to great use!"



This gives us a solid basis for characterizing and optimizing power consumption of our next generation of devices

The technology ... will lead to a commercialized product that increases safety of assets & goods & ensures on-time delivery

Irish SME: Service provider for remote autonomous level monitoring in silos (FhG-IMS).



Dust formation during filling of silos causes a dust deposit on the optics of the sensor creating problems with level detection. The study assesses photovoltaic energy harvesting for the supply of the IoT sensor and lens cleaning and builds an initial demonstrator.

"Our sensors sit in silos typically containing powder that get congested. The feasibility study showed us that careful power management at controlled intervals would enable us to activate self-cleaning sensors. Expertise from EnABLES in future could help us select the optimal sizing & intervals of the sensor cleaning system that would last >10 years. This dramatically reduces the maintenance needed on silos & related costs."



Austrian SME: Energy harvesting power supplies for GPS trackers on railway trains (FhG-IIS).



Completely self-powered autonomous operation was found to be realistic for the specified use-cases. The technology is planned for adoption in a German public funded project which will lead to a commercialised product that increases the safety of assets and goods and ensures an on-time delivery.

"Very smooth process from first contact. Availability of Fraunhofer IIS was really good. Answers and technical input were punctual and very accurate. Very direct collaboration, the agenda of the project and the setup was clear to everyone. In addition, two-weekly conference calls helped to fulfill the aim of the project."



The feasibility study showed us that careful power management at controlled intervals would enable us to activate self-cleaning sensors





Check out our position paper

<https://www.enables-project.eu/outputs/position-paper/>



EnABLES

European Infrastructure
Powering the Internet of Things

Research
Infrastructure
Position Paper

EnABLES Grant
agreement
730957



Integrating and Opening Existing
National and Regional Research
Infrastructures of European Interest



Acknowledgements

This work was supported by the European Union Horizon 2020 project EnABLES, grant agreement no 730957

Thanks!
Go raibh maith agaibh! 

Mike Hayes
michael.hayes@tyndall.ie
+353 87 2887294