

The logo for PE SYSTEMS features the text "PE SYSTEMS" in a dark blue, sans-serif font. The letters "P" and "E" are separated by a red dot, and the "S" and "Y" are separated by another red dot. Two light blue curved lines, one above and one below, connect the "P" to the "E" and the "S" to the "Y".

PE SYSTEMS

Current Power Electronics Design Process

Iterative design process, that always leads to a solution ...

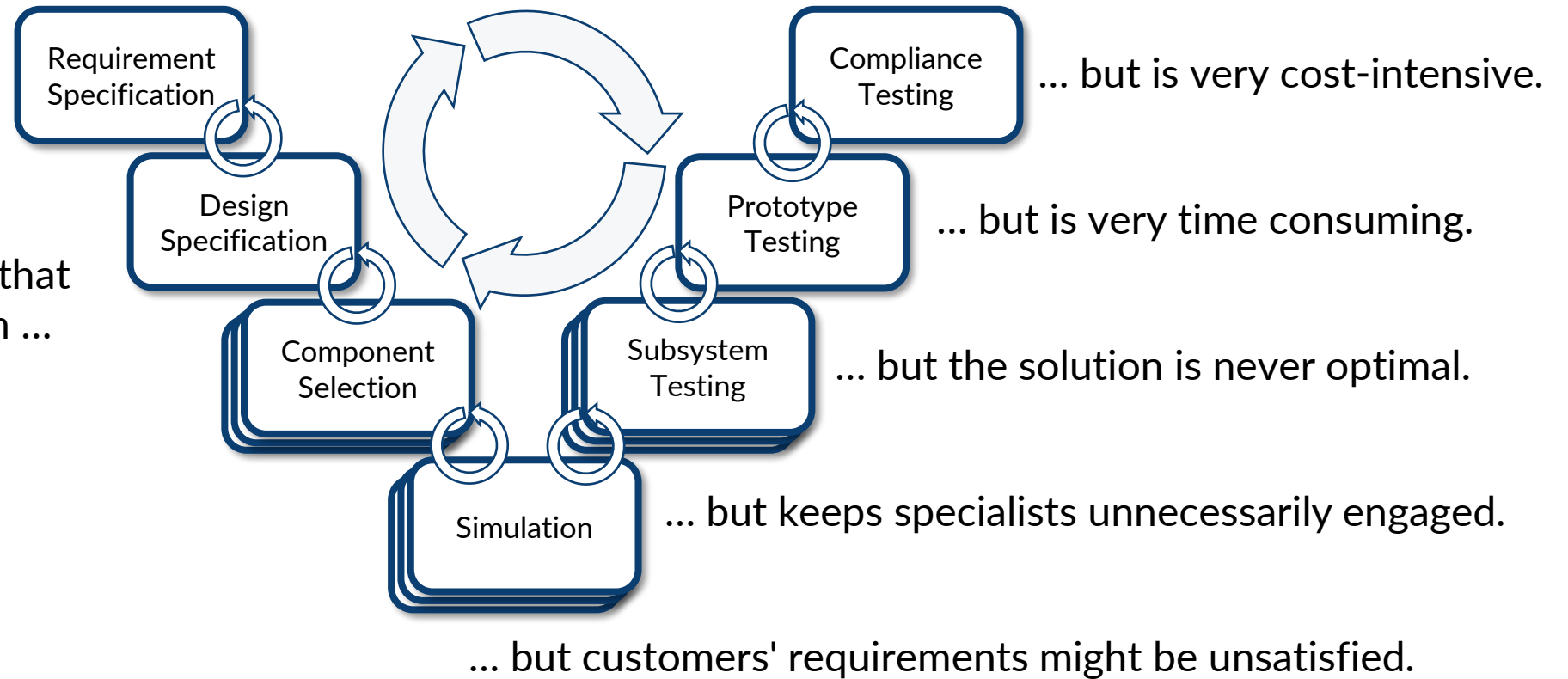

Growing Complexity

Shorter Time-to-Market

New Technologies



Silicon Carbide

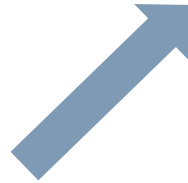

Gallium Nitride



Silicon

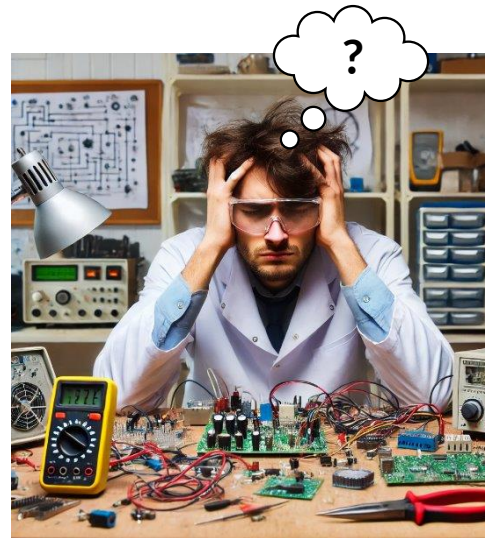

R&D and Design Engineer

New Applications

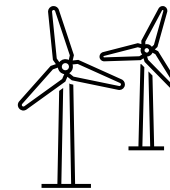
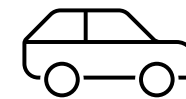
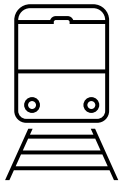
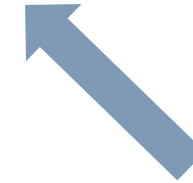

Growing Complexity

Integrated Circuits 1980's

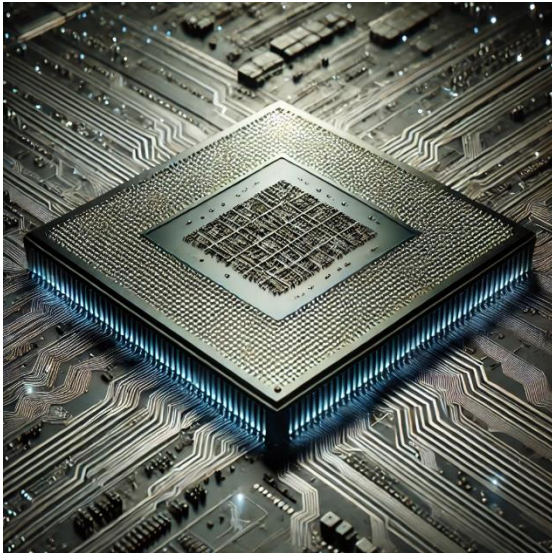

Growing complexity mastered by Electronic Design Automation (EDA)



R&D and Design Engineer

Power Electronics 2020's

1. Component data are not available in the required quantity and quality
2. Power electronics conversion systems involve supply of multiple vendors
3. More degrees of freedom



**Creates solutions for Design
Automation in Power
Electronics**

Data Driven Design

Characterization

- Automated
- Traceable
- Reproducibility
- Uncertainty Quantification

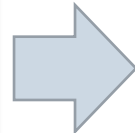

Machine-readable Data Sheet

- Unified Format
- Unified Access
- Data Provision by Manufacturers
- Trusted Sources
- Comparability

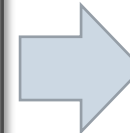
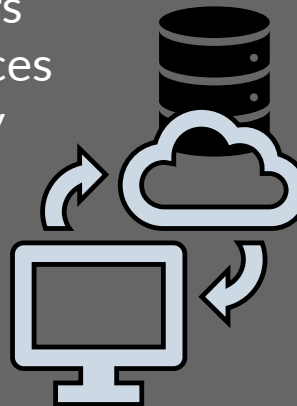

Design Flows

- Automated
- Model-based Design Synthesis
- Large Number of Evaluated Systems
- Handle Uncertainty

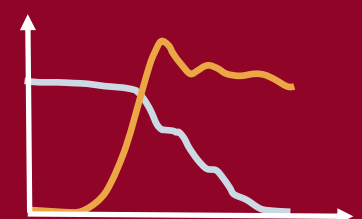
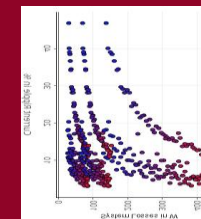

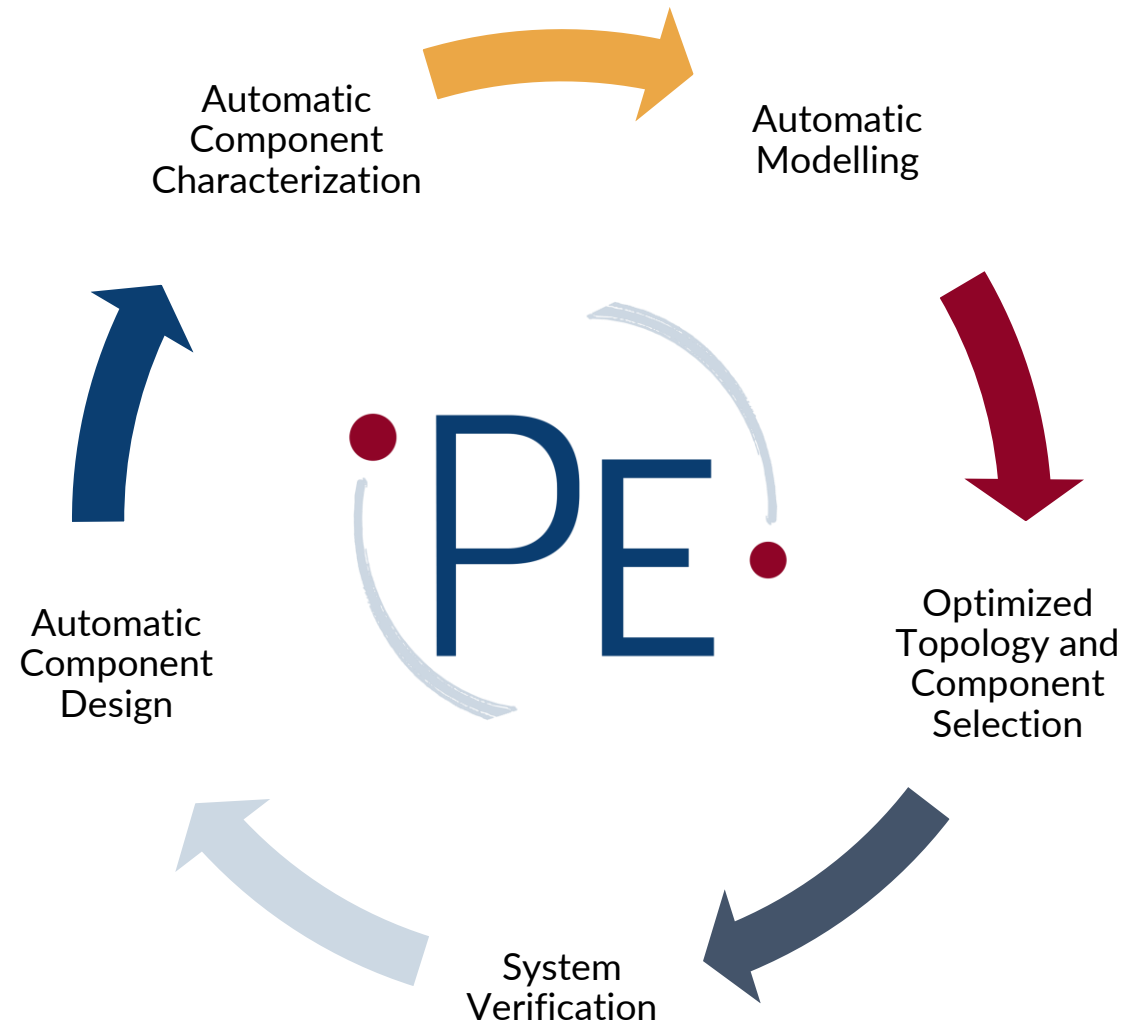

Double-Pulse Test

Switching Losses

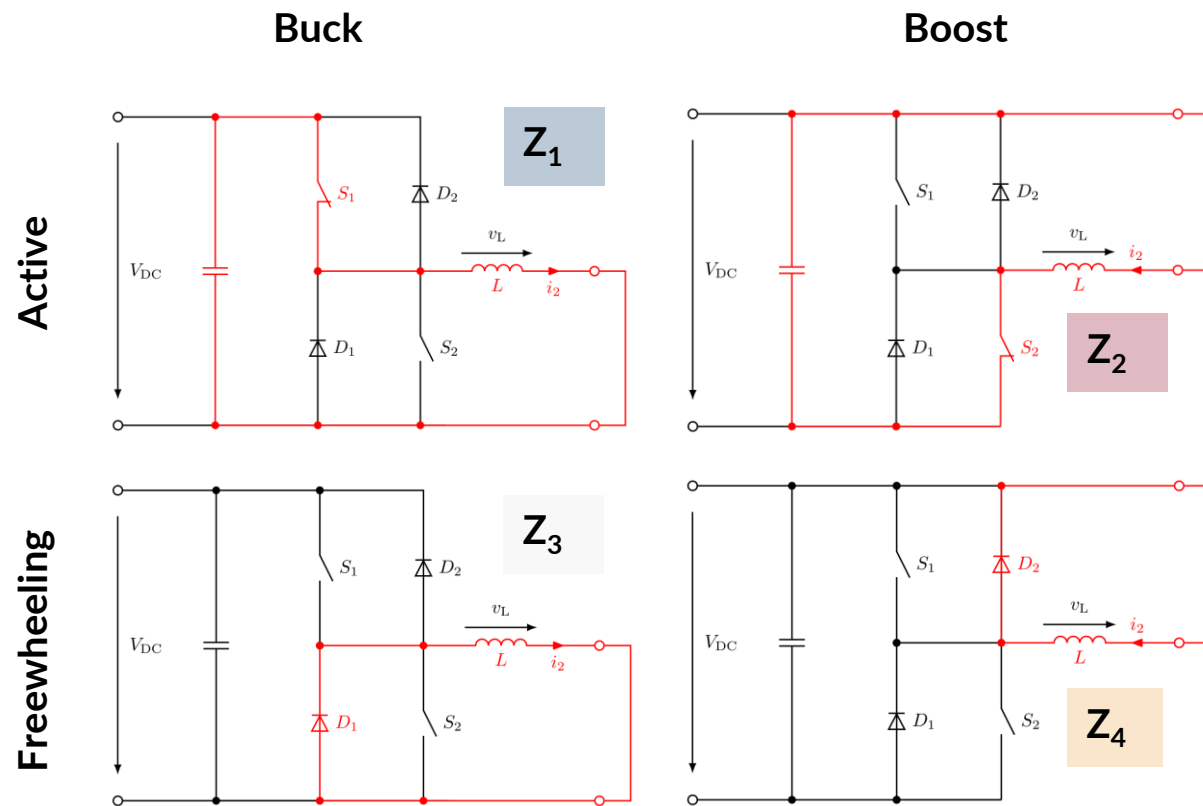
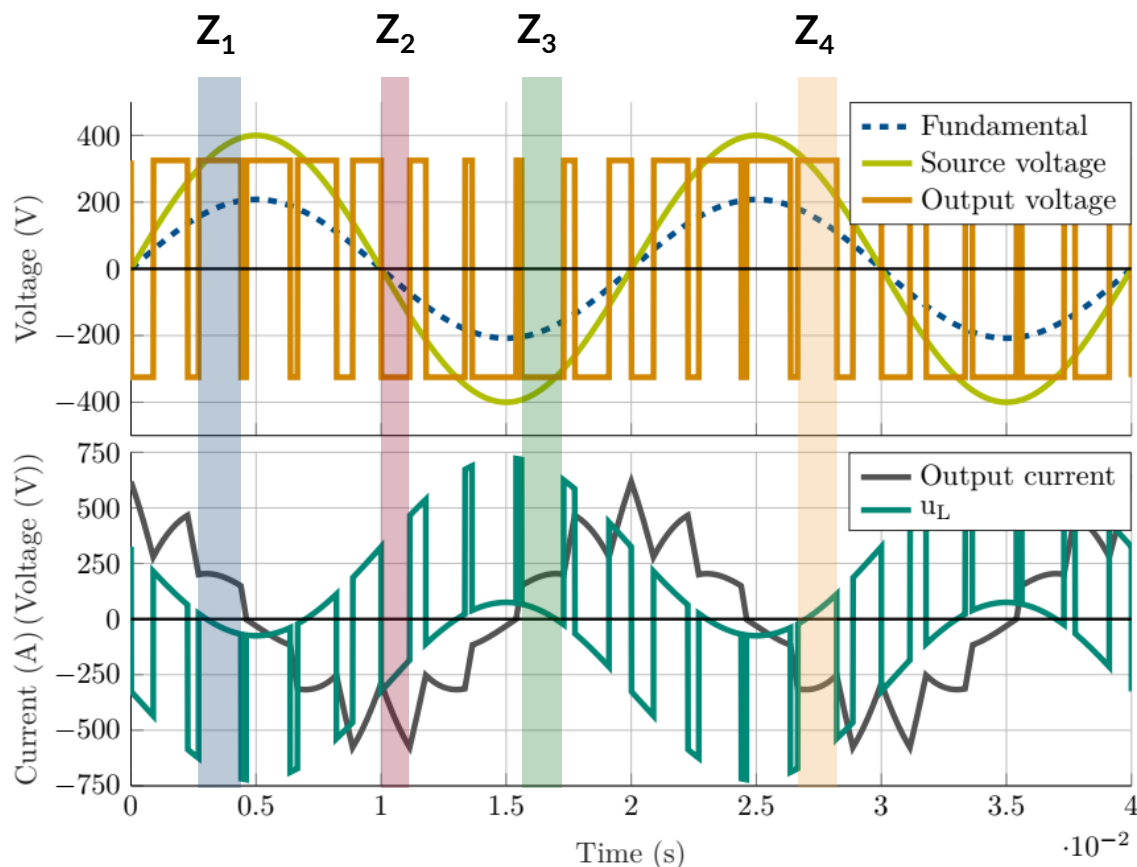

Switching losses are dependent on many parameters

→ Testing close to application

Testing of Inductive Switching

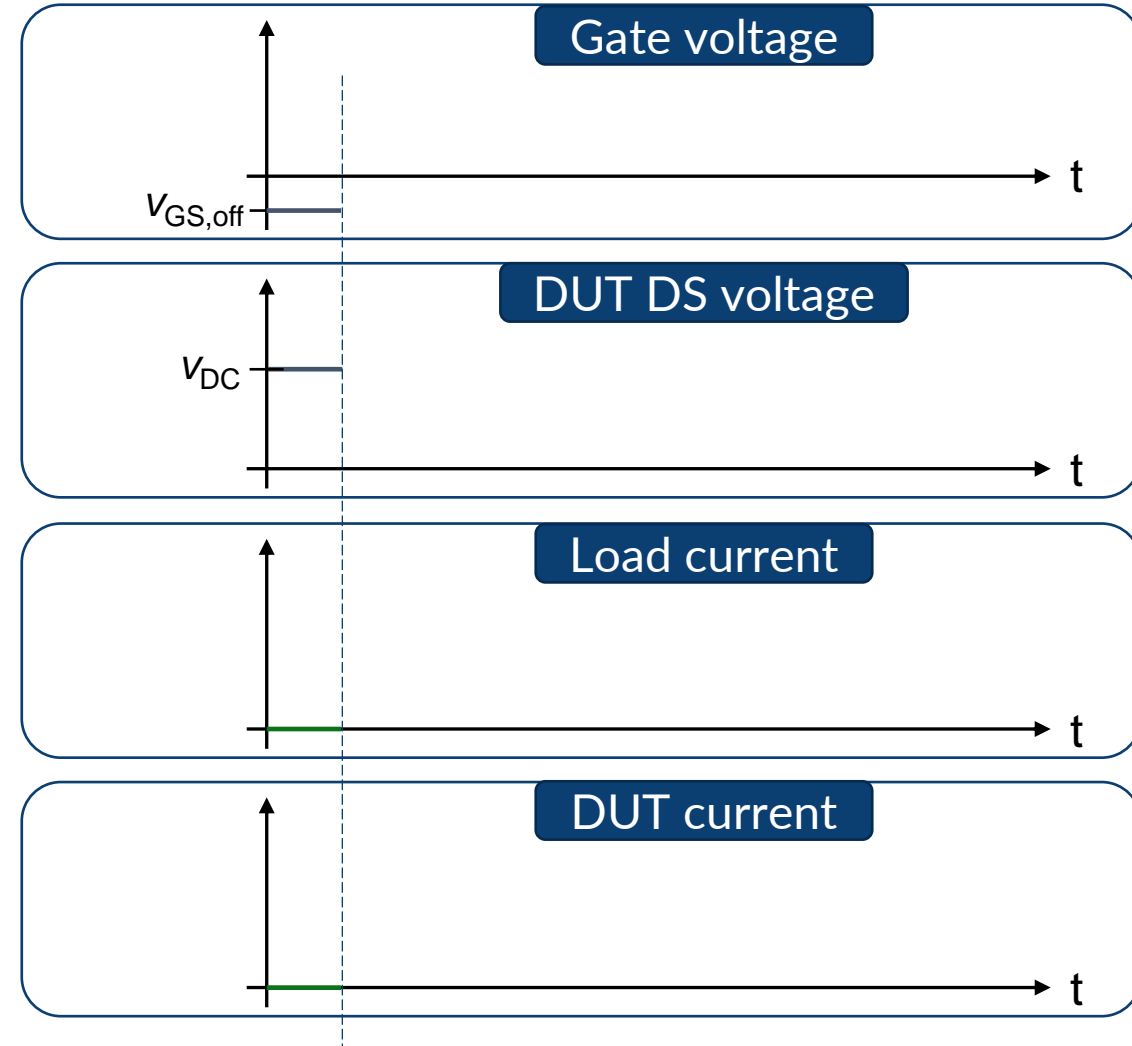
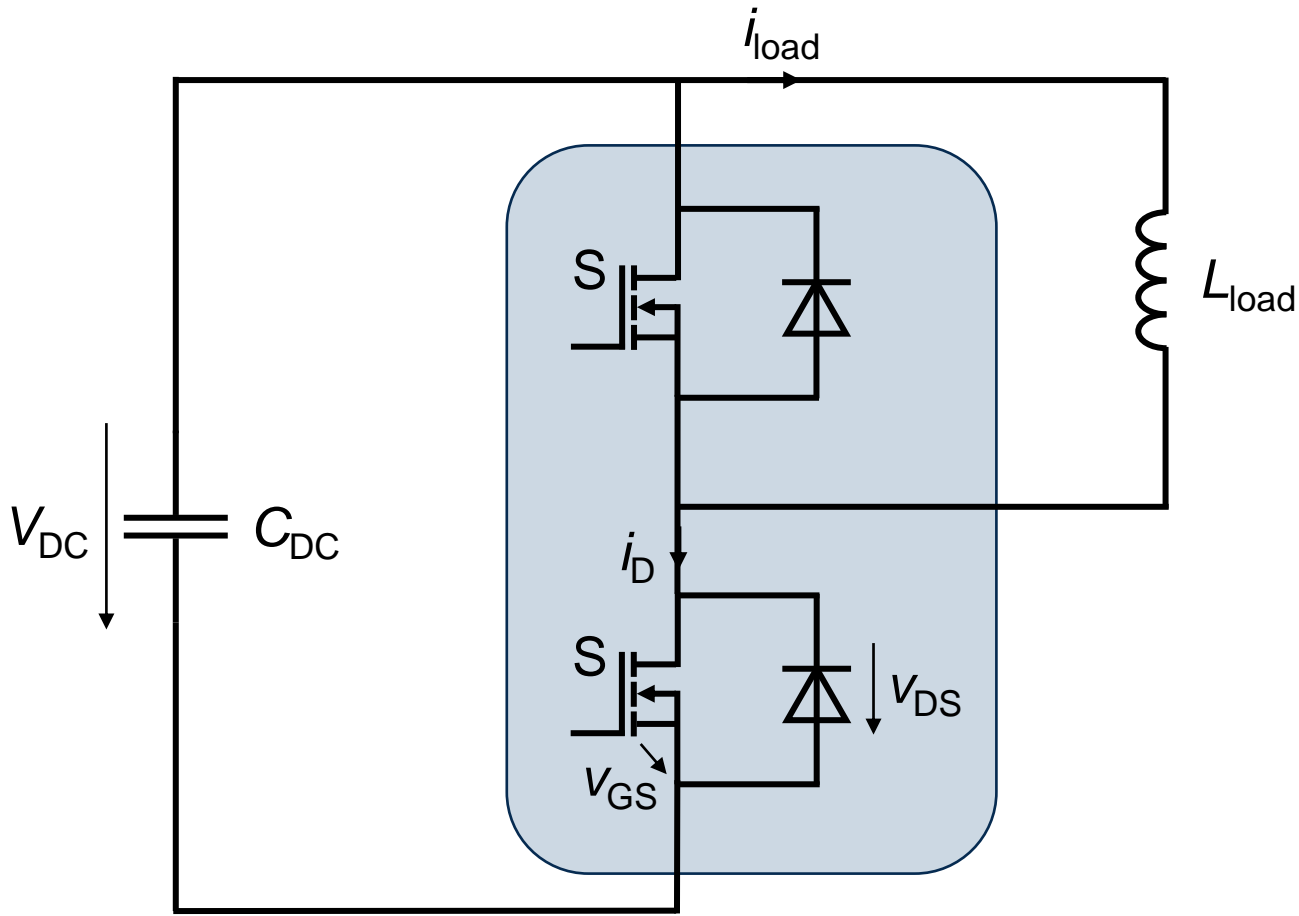

Testing of Inductive Switching

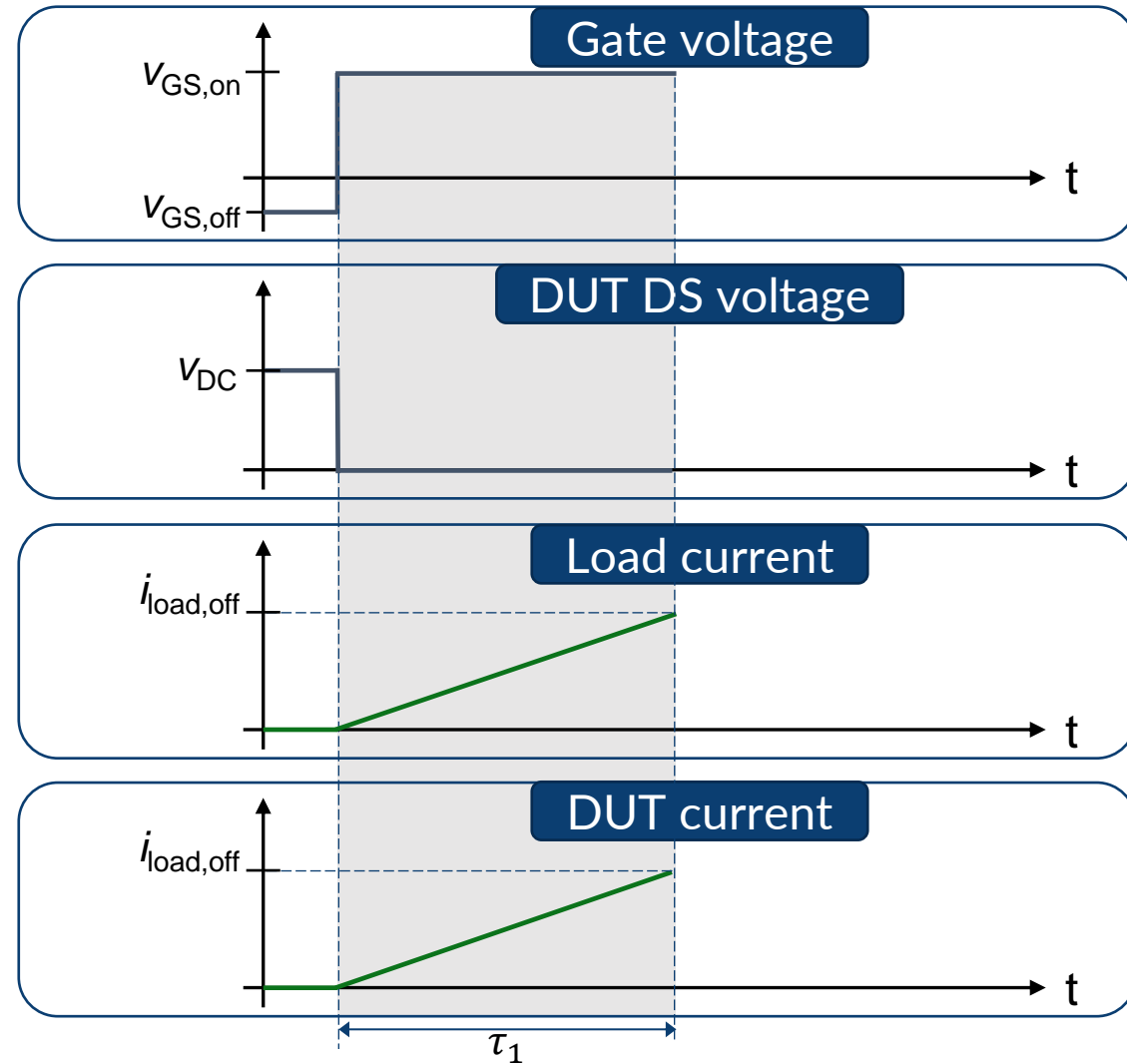
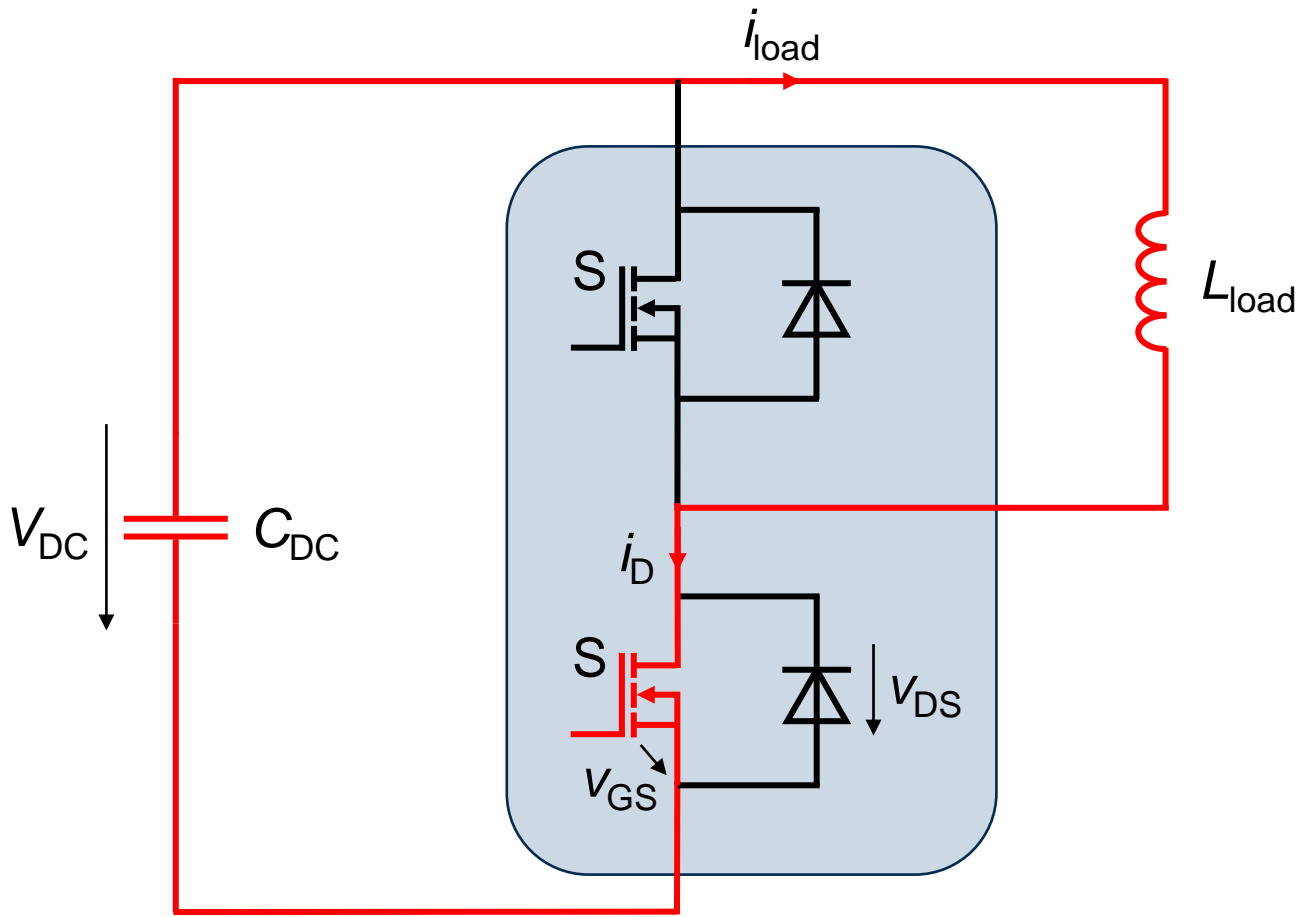

Testing of Inductive Switching

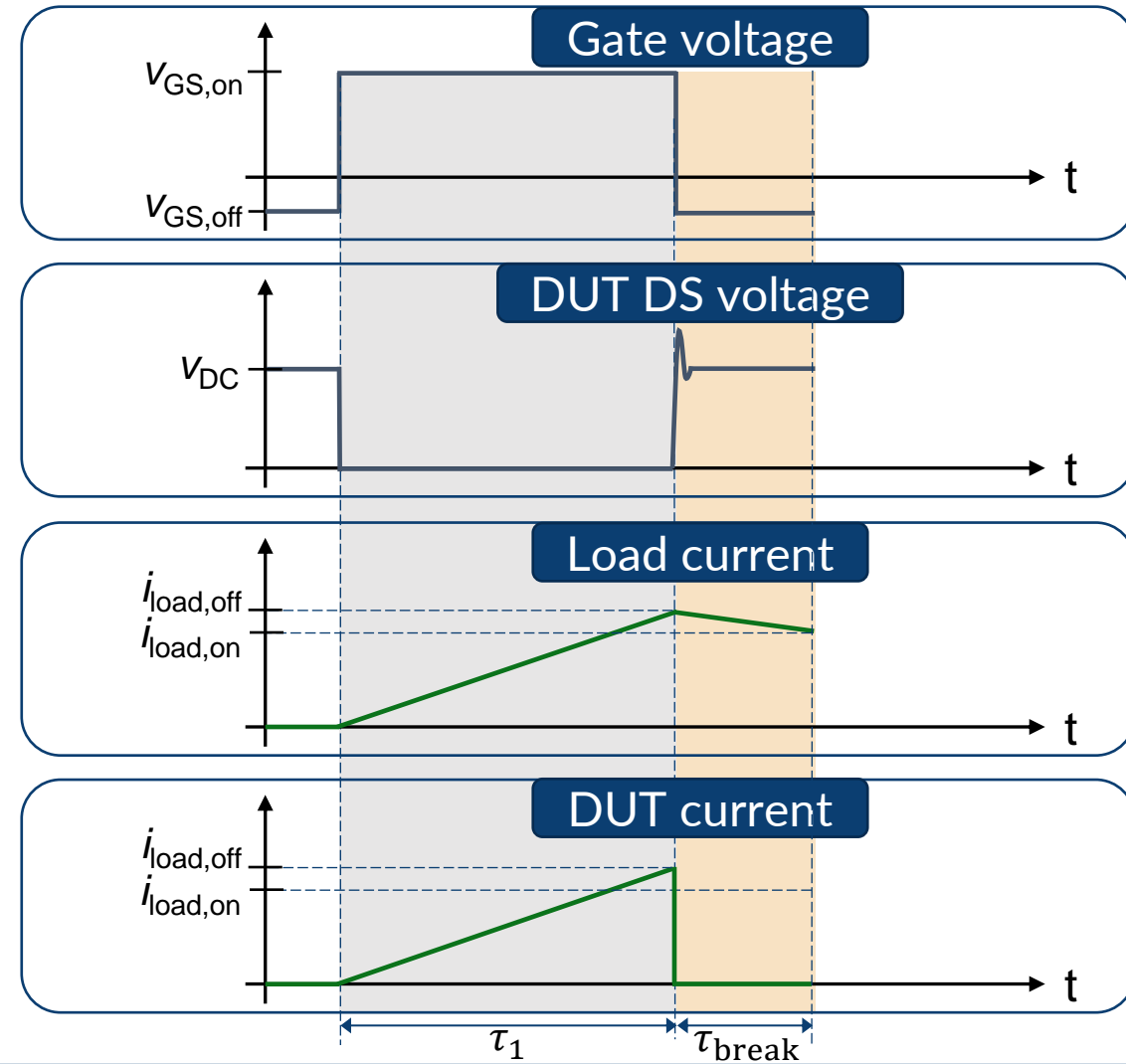
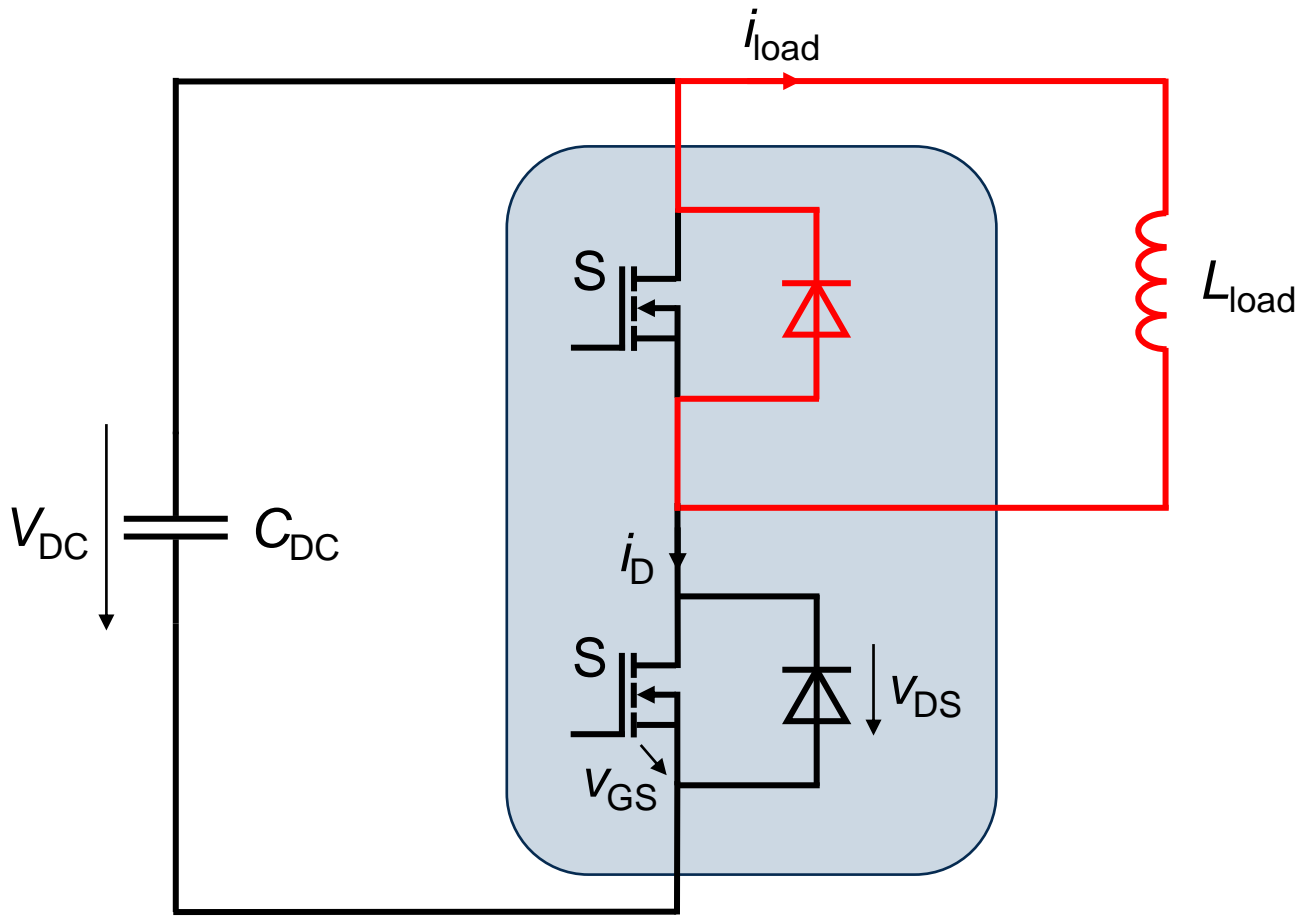

Testing of Inductive Switching

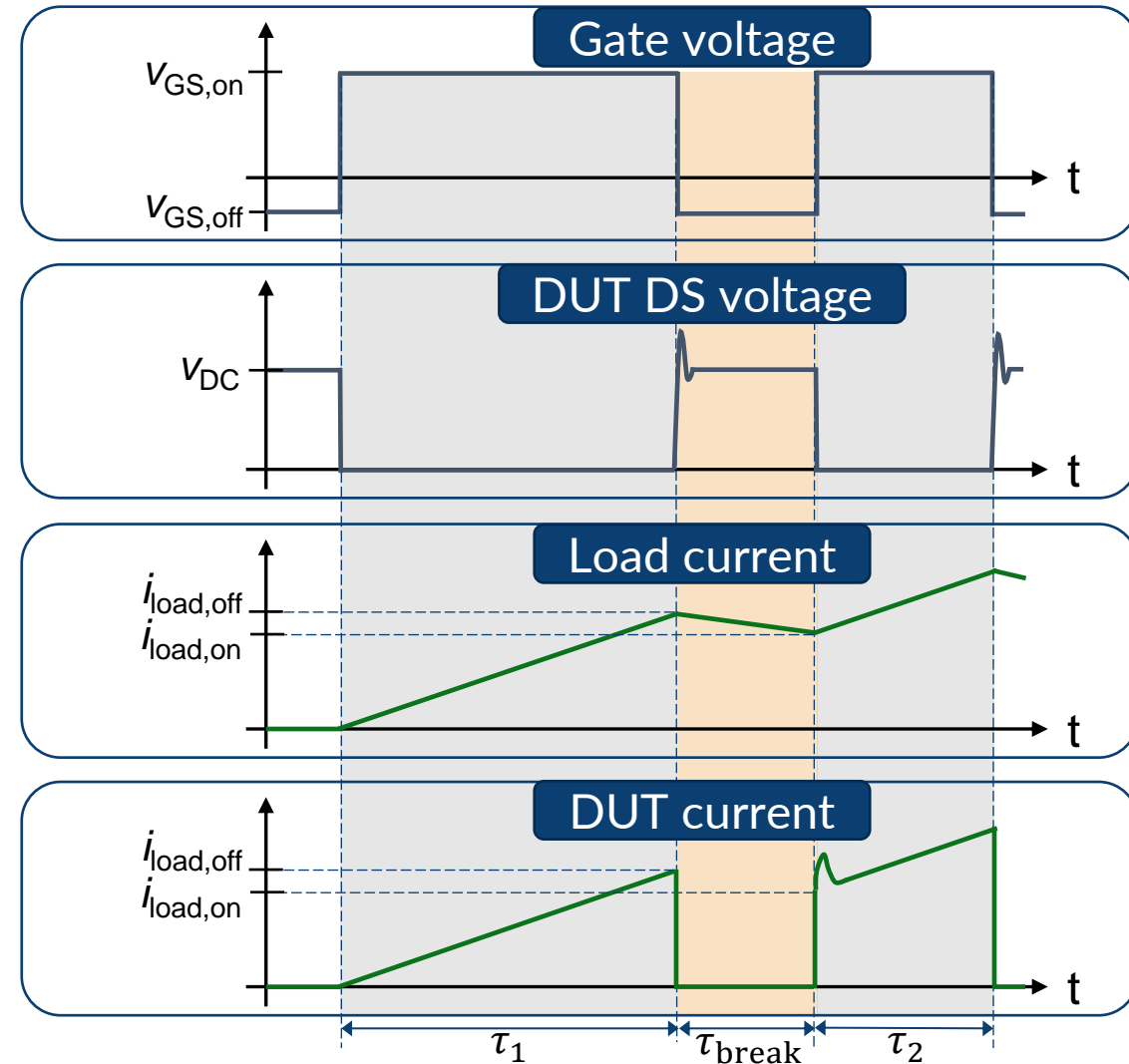
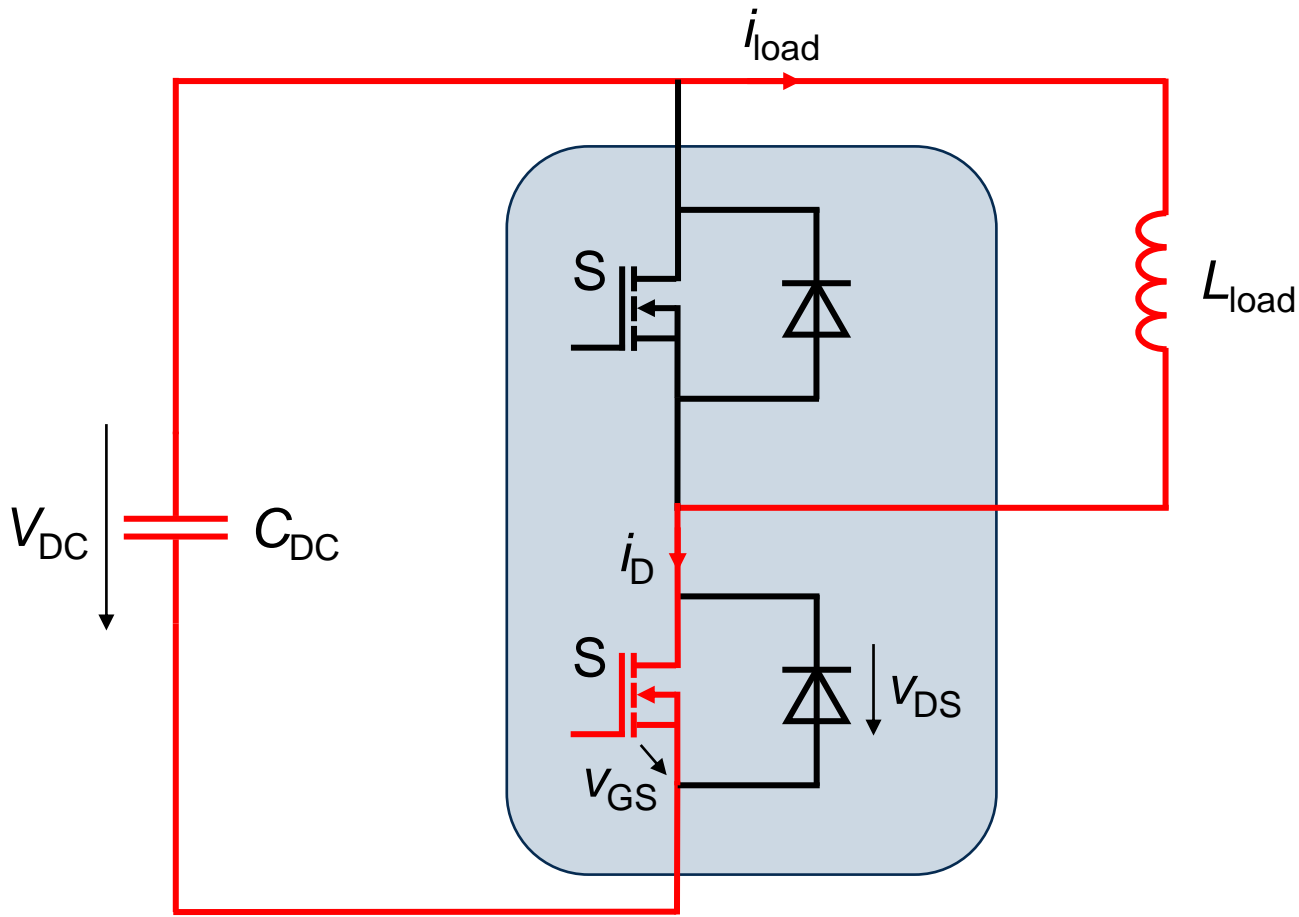

One Test System for Many Applications

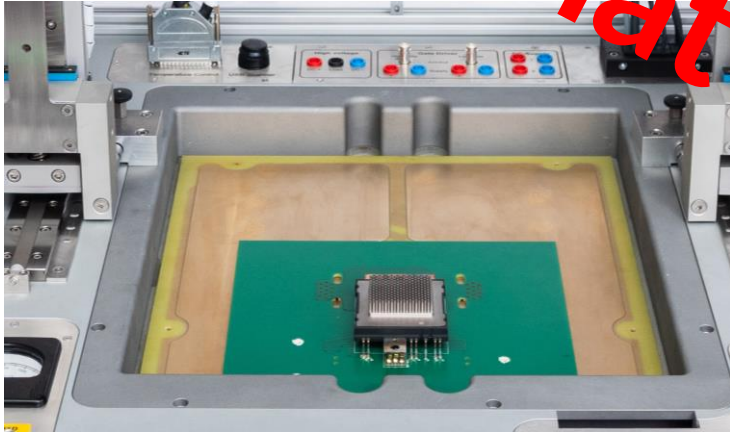

What about the Passives?

Device Characterization

- Discretes and Power Modules
- SiC, GaN & Si
- Optimized Switching Cell
- Minimal Stray Inductance
- Fast, Reliable & Trustworthy

Driver Optimization

- Automatic Search for Gate Parameters
- Programmable Gate Drivers
- Variable Gate Resistors
- Adaptable Gate Voltages
- Short Circuit Test

System Verification

- Testing Close to Application
- Complete Power Stage Testing
- Flexible and Ergonomic Workbench
- Reproducible Results

Testing of Inductive Switching

DUT

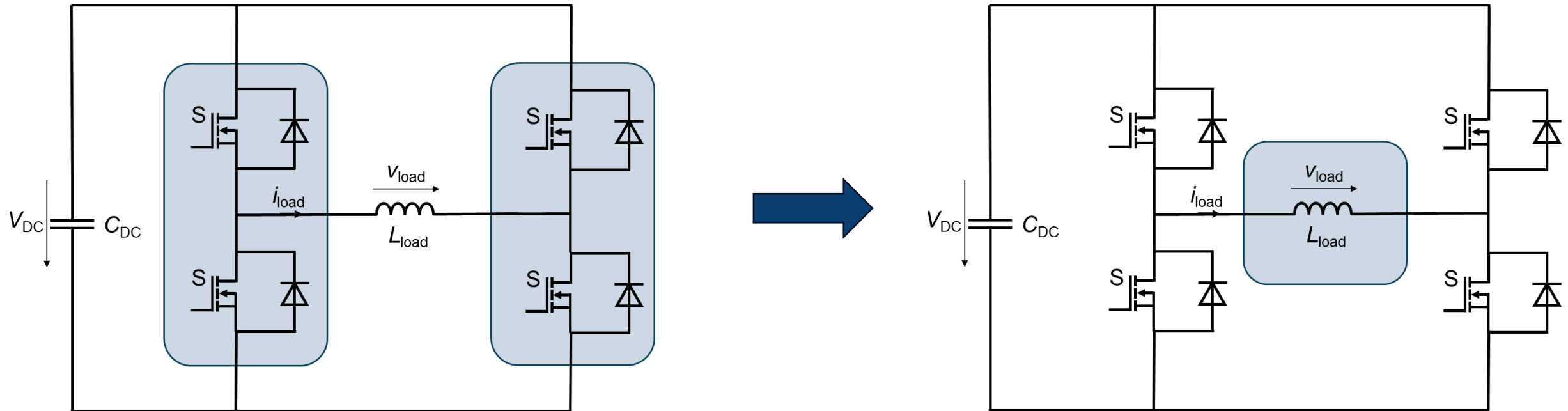

Sequences

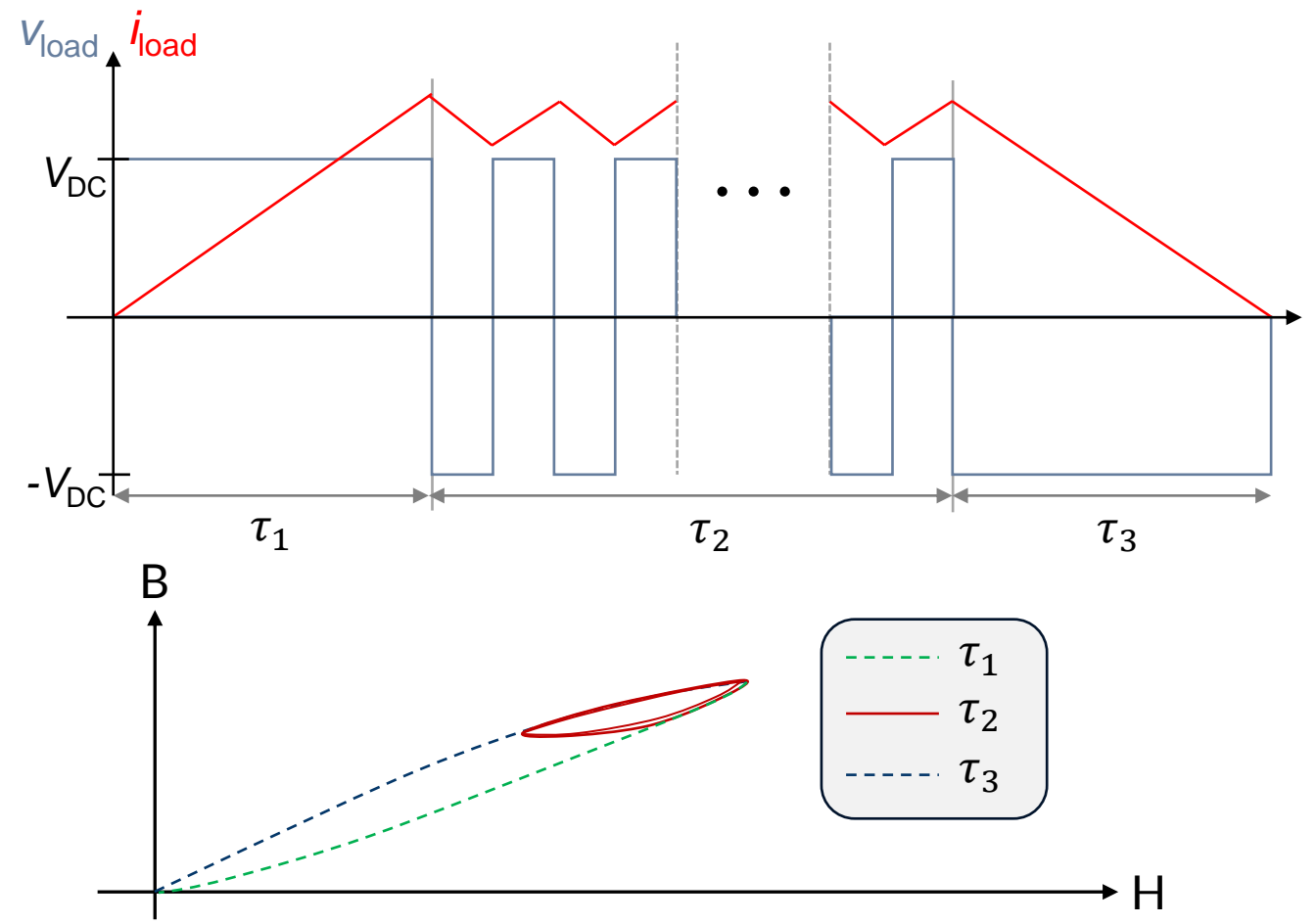
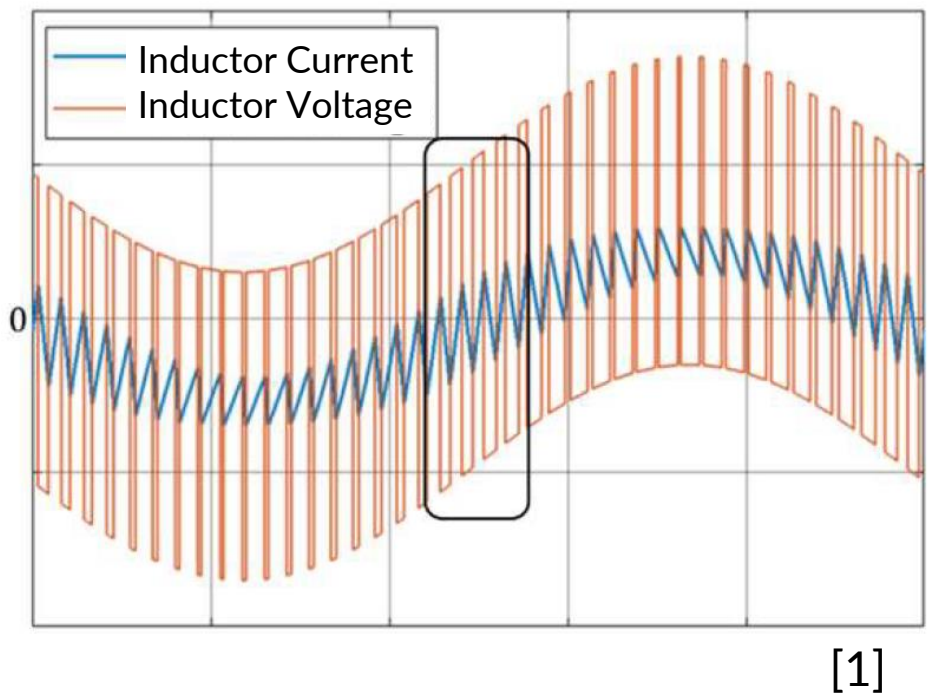

[1] Wang, Jun & Yuan, Xibo & Rasekh, Navid. (2020). Triple Pulse Test (TPT) for Characterizing Power Loss in Magnetic Components in Analogous to Double Pulse Test (DPT) for Power Electronics Devices.

Measurement Setup

Picture Missing



Automatic De-Skew

De-skew issue

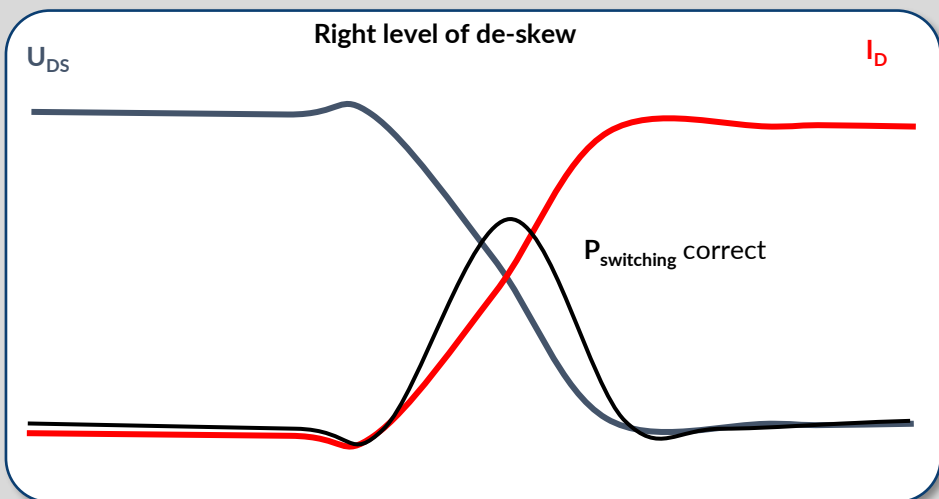
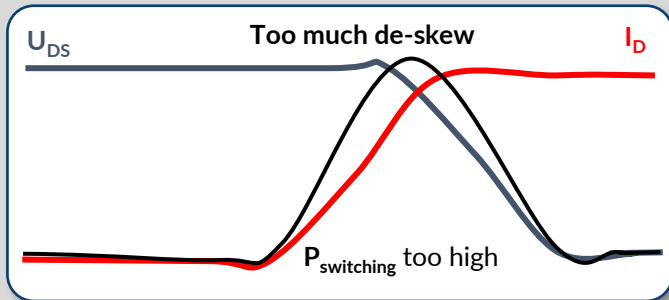
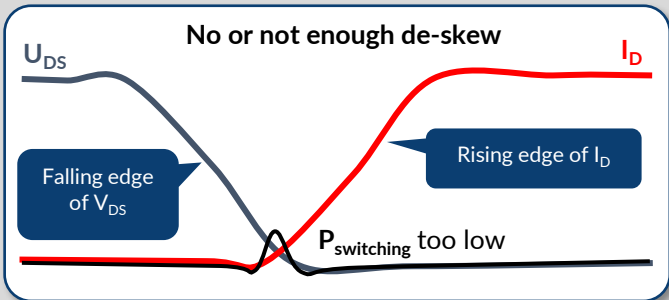

Automatic de-skew

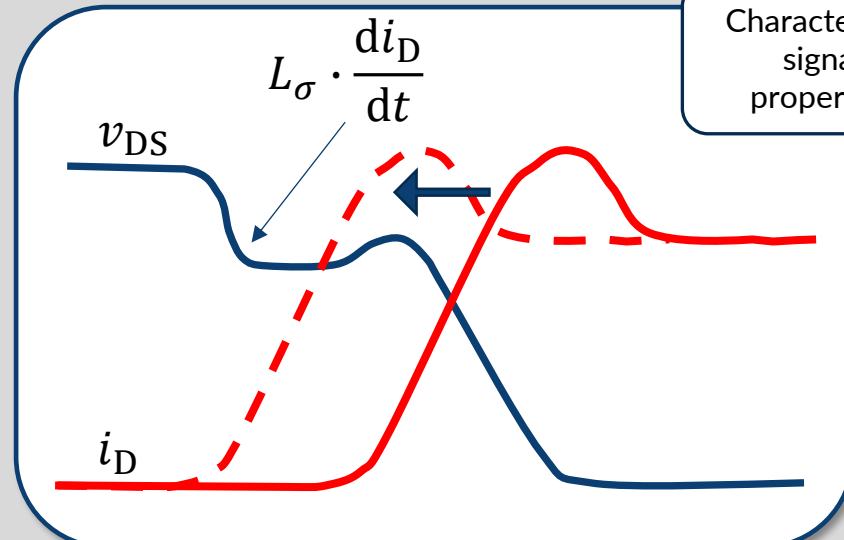

Calculated for each signal

Statistically extracted skew

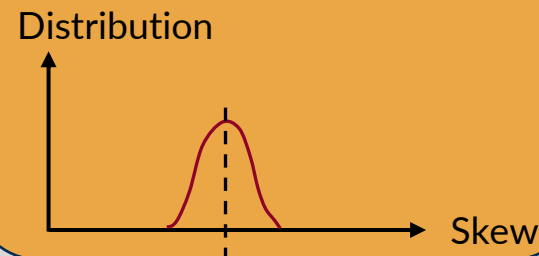

Automatic De-Skew Realization

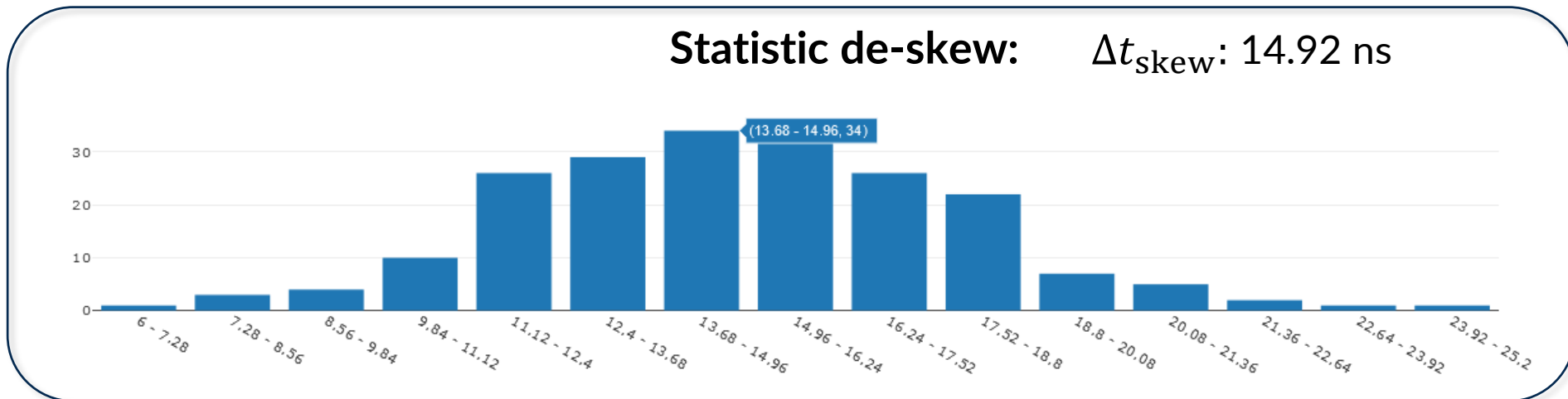
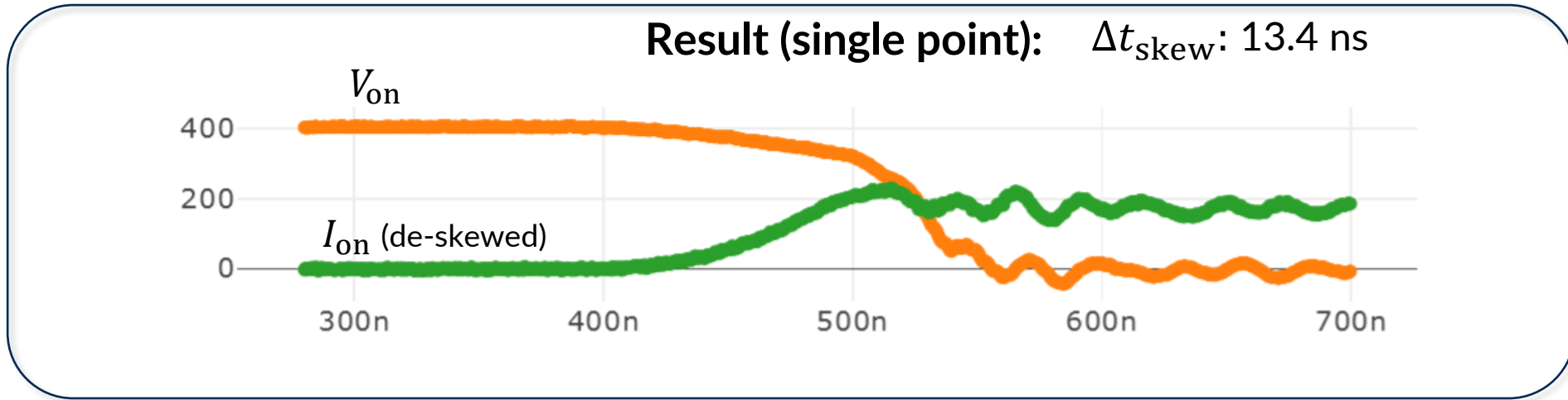

Solutions

Device Tester + Automation Software

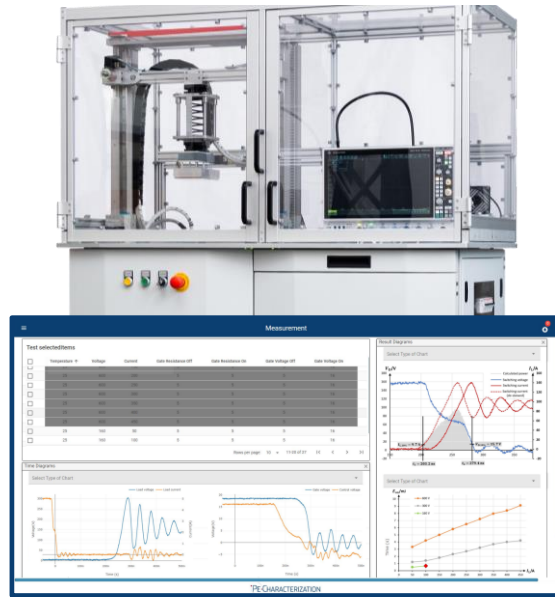

Automation Software

Standalone software uses existing equipment

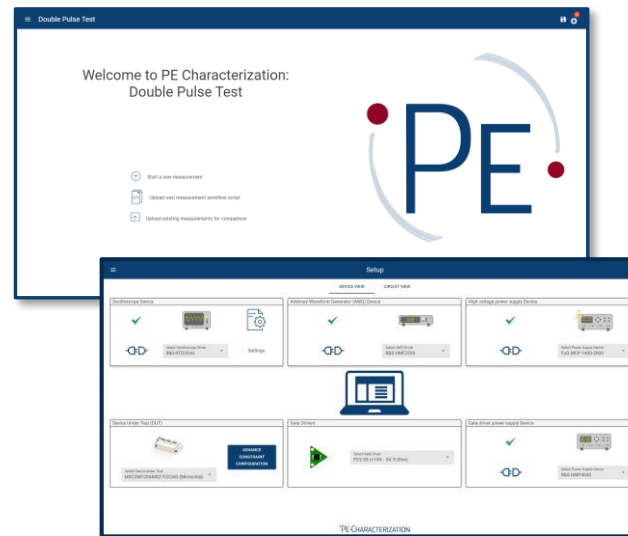

Measurement as a Service Characterization

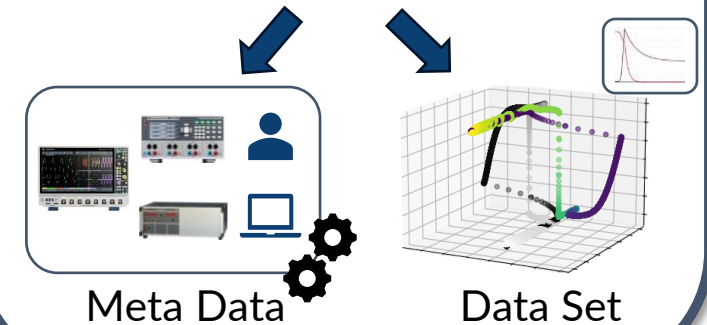

What comes next?

Contact



PE-Systems GmbH
Landwehrstrasse 55
64293 Darmstadt
Germany



contact@pe-systems.de



+49 6151 4934717

Modular Double-Pulse Tester

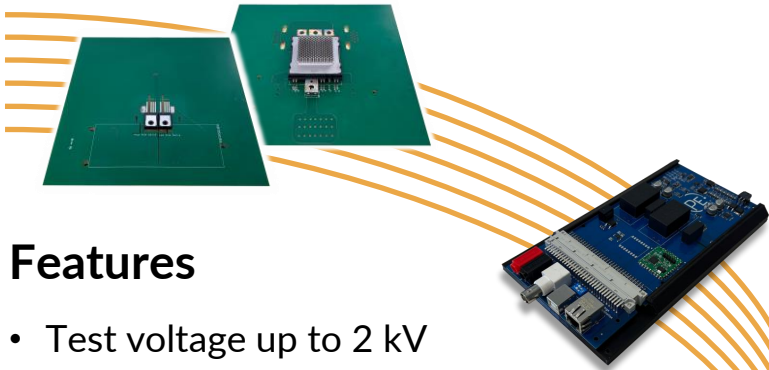

Features

- Test voltage up to 2 kV (4.5 kV coming soon)
- Test current up to 3.6 kA
- Test temperature 25°C to 250 °C / -55°C to 250°C with ThermoStream
- Optimized test fixtures for all packages
- Universal gate drivers
- Different load inductors and DC-links
- Very low stray inductance
- High performance scope and probes of multiple vendors or integration of pre-existing equipment

Benefits

- Modules, discrettes, silicon, SiC and GaN – one tester for all devices
- Fast setup times
- Avoidance of human errors through error-detecting software
- Fast amortization due to reduction of required human resources
- Use of existing infrastructure (compatibility)

Be prepared for upcoming challenges!

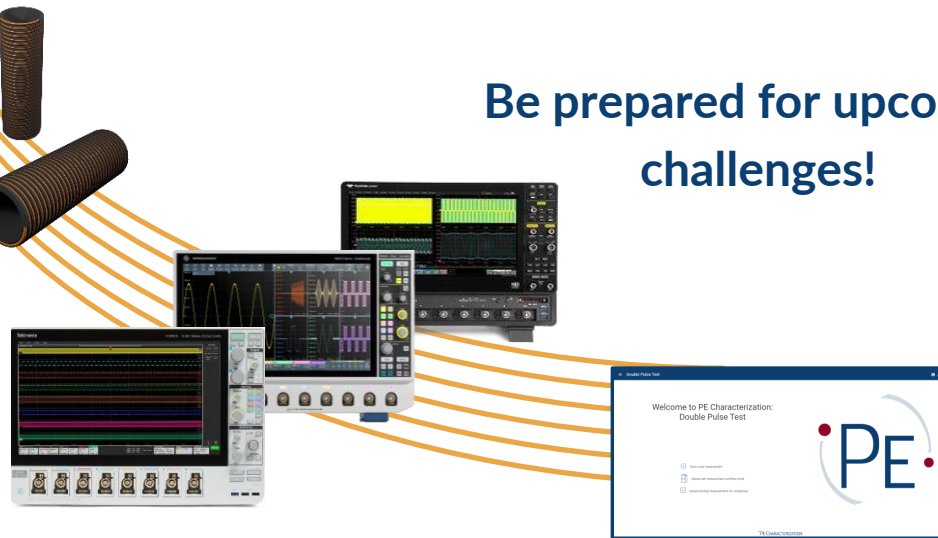

DPT Solutions - Overview



Base frame:

+ Additional Equipment



Base cabinet

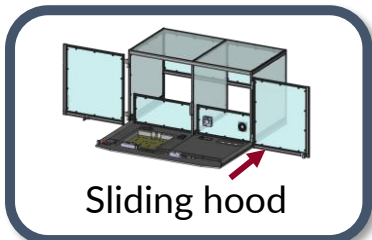

Sliding hood

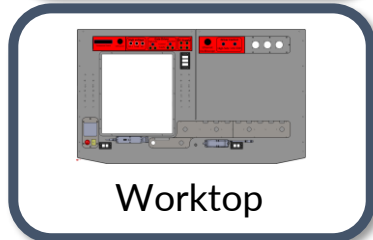

Worktop



Safety Circuit



Contacting Unit

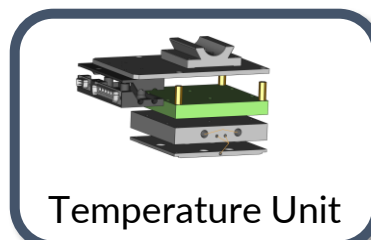

Temperature Unit



Universal Driver

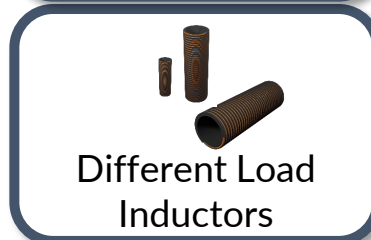

Different Load Inductors



High Voltage Source



ThermoStream

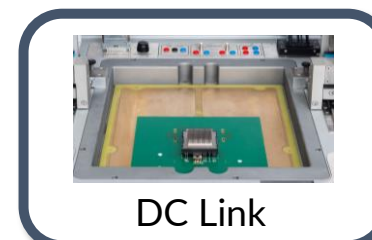

DC Link



High-Performance Measurement Equipment

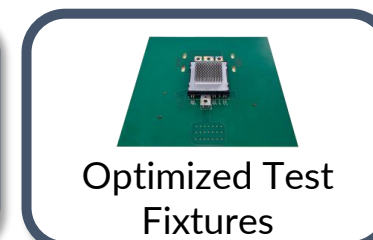

Optimized Test Fixtures



Laboratory Source



Automation Software



Training / Service